

# DK-LOK

Fittings & Valves

## DK-Lok UHP Fittings

No.09-01(E)  
May 2017



**Clean Weld Fittings**

Micro Elbow  
**WML** 05



Micro Tee  
**WMT** 05



Micro Cross Tee  
**WMX** 05



Micro Tribow  
**WMTB** 06



Micro Half Elbow  
**WMHL** 06



Micro Reducing Elbow  
**WMRL** 06



Micro Reducing Tee  
**WMRT** 07



Micro Reducer  
**WMR** 07



Long Elbow  
**WL** 08



Long Tee  
**WT** 08



Long Reducing Tee  
**WRT** 08



Long Cross Tee  
**WX** 09



Long Reducer  
**WR** 09



Auto Butt Weld Long Elbow  
**WLA** 09



Auto Butt Weld Long Tee  
**WTA** 10



Auto Butt Weld Long Cross Tee  
**WXA** 10



Auto Butt Weld Long Reducing Tee  
**WRTA** 10



Auto Butt Weld Union  
**WUA** 11



Auto Butt Weld Reducing Union  
**WRUA** 11



**Metal Gasket Face-Seal Fittings**

Short Gland  
**SG** 13



Long Gland  
**LG** 13



Auto Butt Weld Short Gland  
**SGA** 14



Auto Butt Weld Long Gland  
**LGA** 14



Male Gland  
**GM** 15



Socket Weld Long Gland  
**GSL** 15



Socket Weld Reducing Long Gland  
**GSR** 15



Socket Weld Short Gland  
**GSS** 16



Tube Adapter Gland  
**GT** 16



Blind Gland  
**BG** 16



Female Nut  
**FN** 16



Male Nut  
**MN** 17



Cap  
**CP** 17



Plug  
**PG** 17



Gasket  
**GK** 18



Gasket Retainer <b>GKT</b>		18	Union Elbow <b>L</b>		22	High Flow Female Nut <b>HFN</b>		26
Gasket Blind <b>GKB</b>		18	Union Tee <b>T</b>		22	High Flow Male Nut <b>HMN</b>		26
Double Male Union <b>MU</b>		19	Union Cross Tee <b>X</b>		23	Tube Fitting to Auto Butt Weld Connector <b>DATW</b>		26
Double Male Reducing Union <b>MRU</b>		19	Male NPT Elbow <b>ML-N</b>		23	<b>Welded Assembly Fittings</b>		
Bulkhead Union <b>BHU</b>		19	Coupling <b>C</b>		23			
Tube Fitting Connector <b>DC</b>		20	<b>High Flow Fittings</b>			Swivel Female Union <b>SFU</b>		27
Tube Fitting Bulkhead Connector <b>DBHC</b>		20	High Flow Gland <b>HG</b>		24	Swivel Male NPT Connector <b>SMC-N</b>		27
Male NPT Connector <b>MC-N</b>		20	High Flow Reducer <b>HR</b>		24	Swivel Female NPT Connector <b>SFC-N</b>		28
Female NPT Connector <b>FC-N</b>		21	Auto Butt Weld High Flow Reducer <b>HRA</b>		24	Swivel Tube Fitting Connector <b>SDC</b>		28
Bulkhead Male NPT Connector <b>BHMC-N</b>		21	High Flow Bulkhead Reducer <b>HBR</b>		25	Swivel Elbow <b>SL</b>		28
Tube Butt Weld Bulkhead Connector <b>BHTW</b>		21	High Flow Union Elbow <b>HL</b>		25	Swivel Tee <b>ST</b>		29
Straight Thread O-Ring Seal Male Connector <b>MC-UO</b>		22	High Flow Union Tee <b>HT</b>		25			

## Ordering Information

DK-Lok Weld Fittings and Metal Face Seal Fittings are ordered by product code shown below.

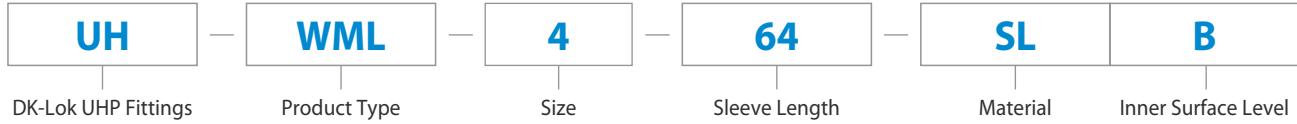

Size	Sleeve Length	Material	Inner Surface Level
4 : 1/4"	64 : 6.4mm	SL : 316L Stainless Steel	B : BA
6 : 3/8"	91 : 9.1mm	DL : 316L Stainless Steel VAR	P : EP
8 : 1/2"	96 : 9.6mm		
12 : 3/4"	191 : 19.1mm		
16 : 1"	244 : 24.4mm		

Product Type			
Micro Fittings		Face Seal Fittings	
WML	Micro 90° Elbow	FN	Female Nut
WMT	Micro Tee	MN	Male Nut
WMX	Micro Cross Tee	CP	Cap
WMTB	Micro Tribow	PG	Plug
WMHL	Micro 45° Elbow	GK	Gasket
WMRL	Micro Reducing Elbow	GKT	Gasket Retainer
WMRT	Micro Reducing Tee	GKB	Gasket Blind
WMR	Micro Reducer	MU	Double Male Union
<b>Tube Butt Weld Fittings</b>		BHU	Bulkhead Union
WL	Long Elbow	DC	DK-Lok Tube Fitting Connector
WRL	Long Reducing Elbow	DBHC	DK-Lok Bulkhead Tube Fitting Connector
WT	Long Tee	MC-N	Male NPT Connector
WRT	Long Reducing Tee	FC-N	Female NPT Connector
WX	Long Cross Tee	BHMC-N	Bulkhead Male NPT Connector
WR	Long Reducer	BHTW	TBW Bulkhead Connector
<b>Face Seal Fittings</b>		MC-UO	O-ring Seal Male Connector
SG	Female Gland	L	Union Elbow
LG	Male Gland	T	Union Tee
SGA	Automatic Female Gland	X	Union Cross Tee
LGA	Automatic Male Gland	C	Coupling
GM	Male Weld Gland	HG	High Flow Gland
GSL	Socket Weld Long Gland	HR	High Flow Reducer
GSR	Socket Weld Reducing Long Gland	HRA	Automatic High Flow Reducer
GSS	Socket Weld Short Gland	HFN	High Flow Female Nut
GT	Tube Adapter Gland	HMN	High Flow Male Nut
BG	Blind Gland	DATW	Tube Fitting to Auto Butt Weld Connector

## Pressure Rating

The pressure ratings provided in this catalogue are obtained by the calculation with the allowable stress of 20,000 psig (1,378 bar) of stainless steel 316 at -20°F (-28°C) to 100°F (37°C) according to ASME B31.3 and B31.1 code.

Pressure derating factors are driven by temperatures greater than 100°F (37°C). They are determined from these pressure code listed in the table 1 and in accordance with ASME B31.3 and B31.1 code. Multiply the applicable pressure rating in this catalogue by the factor in the table 1 to determine the working pressure.

Table 1. Derating Factor

Material	SS 316	SS 316L
Temperature °F (°C)	Derating Factor	
-20 (-28) ~ 100 (37)	1.00	1.00
~ 200 (93)	1.00	0.83
~ 400 (204)	0.96	0.77
~ 600 (315)	0.85	0.67
~ 800 (426)	0.79	0.62
~ 1000 (537)	0.76	0.56

## Material

Material	Designation	Specification	
		Bar stock	Forging
316L Stainless Steel	SL	ASME SA479	ASME SA182
316L Stainless Steel VAR	DL	ASTM A479/A276	ASME A182

## Cleaning & Packing

Passivation is done in accordance with ASTM A380, Ultra-sonic cleaning in a class 100 clean room environment, implemented with resistivity over 18MΩ D.I water after finishing the passivation for precision cleaning. After cleaning, the product receives double packaging in a clean room environment using anti-static polyethylene bags and high purity nitrogen inclusion.

## Surface Roughness

Grade	Designation	Surface Level	
BA	B	$R_a : 10 \mu\text{in}$	$R_y : 3.0 \mu\text{m}$
EP	P	$R_a : 5 \mu\text{in}$	$R_y : 0.7 \mu\text{m}$

## Feature

- Accommodates the miniature tubing system
- Allows close parts spacing
- Flow capacity to be equivalent to the conventional big size welding fitting

Rounded Edge : all edges of the product are rounded for safe handling and to help prevent damage the other products

Material Heat code : marked on the product for easy raw material traceability

Laser Marking : shows the manufacturer, material / grade, heat code and process number on the body for easy identification

10  $\mu\text{in}$ .  $R_a$  and 5  $\mu\text{in}$ .  $R_a$  are standard surface finish

For automatic tube butt welding, integral filler ring is provided for proper alignment

Sharp and burr-free tube end :

Radiused Junction : pockets and entrapment zones in the junction portion are eliminated for a smooth flow transition

Accurately machined diameter dimension conforms to tube diameter



For Tees, the run (1 to 2) shall precede the branch(3)

For Crosses, the run (1 to 2) shall precede the branch(3 to 4)

## Clean Weld Fittings

Micro Elbow

### WML

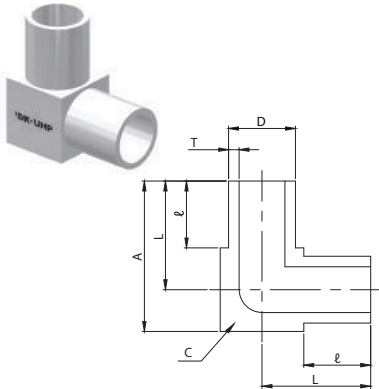

Tube Size (D)	Part No.	Thickness (Tube Wall)		L		ℓ		A		C Body Cube	Working Pressure
		in.	mm	in.	mm	in.	mm	in.	mm		
1/8	UH-WML-2	0.028	0.7	0.41	10.4	0.25	6.4	0.56	14.40	5/16	8500(585)
1/4	UH-WML-4	0.035	0.8	0.41	10.4	0.25	6.4	0.56	14.40	5/16	5100(351)
3/8	UH-WML-6	0.035	0.8	0.47	11.9	0.25	6.4	0.69	17.40	7/16	3300(227)
1/2	UH-WML-8	0.049	1.24	0.53	13.5	0.25	6.4	0.81	20.60	9/16	3700(254)
Metric	Part No.	mm		in.	mm	in.	mm	in.	mm	in.	psig(bar)
6M	UH-WML-6M	1.0		0.41	10.4	0.25	6.4	0.56	14.40	5/16	6100(420)
8M	UH-WML-8M	1.0		0.47	11.9	0.25	6.4	0.69	17.40	7/16	4500(310)
10M	UH-WML-10M	1.0		0.47	11.9	0.25	6.4	0.69	17.40	7/16	3500(240)
12M	UH-WML-12M	1.0		0.53	13.5	0.25	6.4	0.81	20.60	9/16	2900(200)

Micro Tee

### WMT

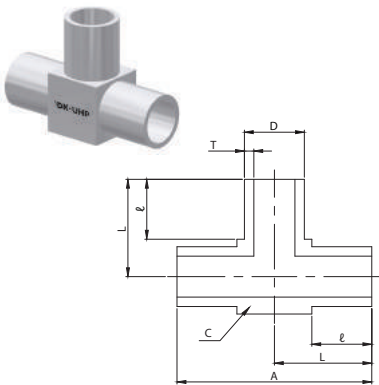

Tube Size (D)	Part No.	Thickness (Tube Wall)		L		ℓ		A		C Body Cube	Working Pressure
		in.	mm	in.	mm	in.	mm	in.	mm		
1/8	UH-WMT-2	0.028	0.7	0.41	10.4	0.25	6.4	0.82	20.80	5/16	8500(585)
1/4	UH-WMT-4	0.035	0.8	0.41	10.4	0.25	6.4	0.82	20.80	5/16	5100(351)
3/8	UH-WMT-6	0.035	0.8	0.47	11.9	0.25	6.4	0.94	23.80	7/16	3300(227)
1/2	UH-WMT-8	0.049	1.24	0.53	13.5	0.25	6.4	1.06	27.00	9/16	3700(254)
Metric	Part No.	mm		in.	mm	in.	mm	in.	mm	in.	psig(bar)
6M	UH-WMT-6M	1.0		0.41	10.4	0.25	6.4	0.82	20.80	5/16	6100(420)
8M	UH-WMT-8M	1.0		0.47	11.9	0.25	6.4	0.94	23.80	7/16	4500(310)
10M	UH-WMT-10M	1.0		0.47	11.9	0.25	6.4	0.94	23.80	7/16	3500(240)
12M	UH-WMT-12M	1.0		0.53	13.5	0.25	6.4	1.06	27.00	9/16	2900(200)

Micro Cross Tee

### WMX

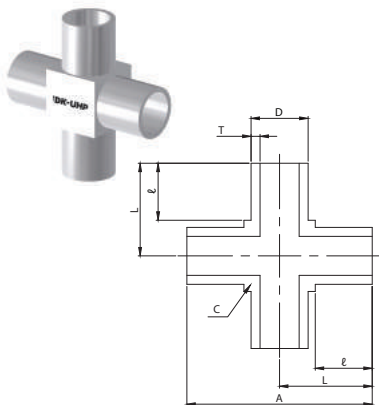

Tube Size (D)	Part No.	Thickness (Tube Wall)		L		ℓ		A		C Body Cube	Working Pressure
		in.	mm	in.	mm	in.	mm	in.	mm		
1/8	UH-WMX-2	0.028	0.7	0.41	10.4	0.25	6.4	0.82	20.80	5/16	8500(585)
1/4	UH-WMX-4	0.035	0.8	0.41	10.4	0.25	6.4	0.82	20.80	5/16	5100(351)
3/8	UH-WMX-6	0.035	0.8	0.47	11.9	0.25	6.4	0.94	23.80	7/16	3300(227)
1/2	UH-WMX-8	0.049	1.24	0.53	13.5	0.25	6.4	1.06	27.00	9/16	3700(254)
Metric	Part No.	mm		in.	mm	in.	mm	in.	mm	in.	psig(bar)
6M	UH-WMX-6M	1.0		0.41	10.4	0.25	6.4	0.82	20.80	5/16	6100(420)
8M	UH-WMX-8M	1.0		0.47	11.9	0.25	6.4	0.94	23.80	7/16	4500(310)
10M	UH-WMX-10M	1.0		0.47	11.9	0.25	6.4	0.94	23.80	7/16	3500(240)
12M	UH-WMX-12M	1.0		0.53	13.5	0.25	6.4	1.06	27.00	9/16	2900(200)

Micro Tribow

**WMTB**

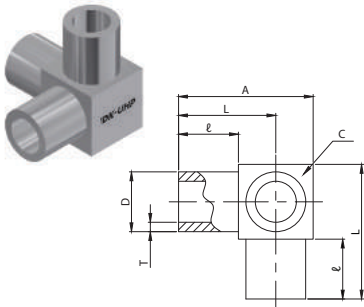

Tube Size (D)	Part No.	Thickness (Tube Wall)		L		ℓ		A		C Body Cube	Working Pressure
		in.	mm	in.	mm	in.	mm	in.	mm		
1/4	UH-WMTB-4	0.035	0.8	0.41	10.4	0.25	6.4	0.56	14.4	5/16	5100(351)
3/8	UH-WMTB-6	0.035	0.8	0.47	11.9	0.25	6.4	0.69	17.4	7/16	3300(227)
1/2	UH-WMTB-8	0.049	1.24	0.53	13.5	0.25	6.4	0.81	20.6	9/16	3700(254)

Micro Half Elbow

**WMHL**

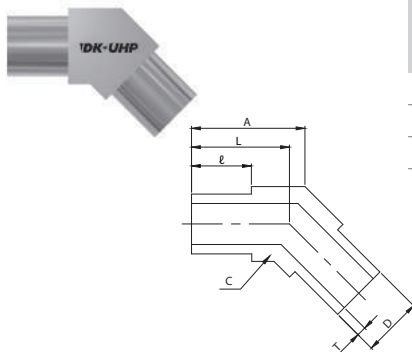

Tube Size (D)	Part No.	Thickness (Tube Wall)		L		ℓ		A		C Body Cube	Working Pressure
		in.	mm	in.	mm	in.	mm	in.	mm		
1/4	UH-WMHL-4	0.035	0.8	0.41	10.4	0.25	6.4	0.47	12.0	5/16	5100(351)
3/8	UH-WMHL-6	0.035	0.8	0.47	11.9	0.25	6.4	0.56	14.2	7/16	3300(227)
1/2	UH-WMHL-8	0.049	1.24	0.53	13.5	0.25	6.4	0.64	16.46	9/16	3700(254)

Micro Reducing Elbow

**WMRL**

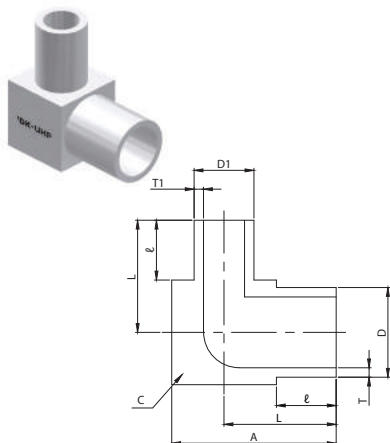

Size (D)	Size (D1)	Part No.	Thickness(Wall) T		Thickness(Wall) T1		L		ℓ		A		C Body Cube	Working Pressure
			in.	mm	in.	mm	in.	mm	in.	mm	in.	mm		
3/8	1/4	UH-WMRL-6X4	0.035	0.8	0.035	0.8	0.47	11.9	0.25	6.4	0.69	17.4	7/16	3300(227)
1/2	1/4	UH-WMRL-8X4	0.049	1.24	0.035	0.8	0.53	13.5	0.25	6.4	0.81	20.6	9/16	3700(254)
1/2	3/8	UH-WMRL-8X6	0.049	1.24	0.035	0.8	0.53	13.5	0.25	6.4	0.81	20.6	9/16	3300(227)
Metric		Part No.	mm		mm		in.		mm		in.		mm	psig(bar)
8M	6M	UH-WMRL-8MX6M	1.0		1.0		0.47		11.9		0.25		6.4	4500(310)
10M	6M	UH-WMRL-10MX6M	1.0		1.0		0.47		11.9		0.25		6.4	3500(240)
12M	6M	UH-WMRL-12MX6M	1.0		1.0		0.53		13.5		0.25		6.4	2900(200)
12M	8M	UH-WMRL-12MX8M	1.0		1.0		0.53		13.5		0.25		6.4	2900(200)

## Micro Reducing Tee

### WMRT

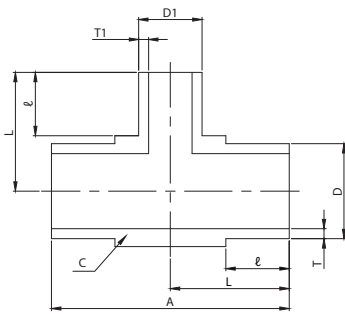
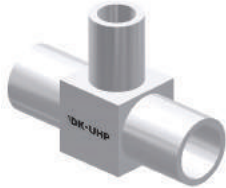

Size (D)	Size (D1)	Part No.	Thickness(Wall) T		Thickness(Wall) T1		L		ℓ		A		C Body Cube	Working Pressure
			in.	mm	in.	mm	in.	mm	in.	mm	in.	mm		
3/8	1/4	UH-WMRT-6X4	0.035	0.8	0.035	0.8	0.47	11.9	0.25	6.4	0.94	23.8	7/16	3300(227)
1/2	1/4	UH-WMRT-8X4	0.049	1.24	0.035	0.8	0.53	13.5	0.25	6.4	1.06	27	9/16	3700(254)
1/2	3/8	UH-WMRT-8X6	0.049	1.24	0.035	0.8	0.53	13.5	0.25	6.4	1.06	27	9/16	3300(227)
Metric		Part No.	mm		mm		in.	mm	in.	mm	in.	mm	in.	psig(bar)
8M	6M	UH-WMRT-8MX6M	1.0		1.0		0.47	11.9	0.25	6.4	0.94	23.8	7/16	4500(310)
10M	6M	UH-WMRT-10MX6M	1.0		1.0		0.47	11.9	0.25	6.4	0.94	23.8	7/16	3500(240)
12M	6M	UH-WMRT-12MX6M	1.0		1.0		0.53	13.5	0.25	6.4	1.06	27	9/16	2900(200)
12M	8M	UH-WMRT-12MX8M	1.0		1.0		0.53	13.5	0.25	6.4	1.06	27	9/16	2900(200)

## Micro Reducer

### WMR

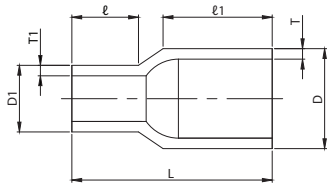

Size (D)	Size (D1)	Part No.	Thickness(Wall) T		Thickness(Wall) T1		L		ℓ		ℓ1		Working Pressure
			in.	mm	in.	mm	in.	mm	in.	mm	in.	mm	
1/4	1/8	UH-WMR-4X2	0.035	0.8	0.028	0.7	0.75	19.1	0.25	6.4	0.41	10.7	5100(351)
3/8	1/4	UH-WMR-6X4	0.035	0.8	0.035	0.8	0.75	19.1	0.25	6.4	0.41	10.7	3300(227)
1/2	1/4	UH-WMR-8X4	0.049	1.24	0.035	0.8	0.75	19.1	0.25	6.4	0.41	10.7	3700(254)
1/2	3/8	UH-WMR-8X6	0.049	1.24	0.035	0.8	0.75	19.1	0.25	6.4	0.41	10.7	3300(227)
Metric		Part No.	mm		mm		in.	mm	in.	mm	in.	mm	psig(bar)
8M	6M	UH-WMR-8MX6M	1.0		1.0		0.75	19.1	0.25	6.4	0.41	10.7	4500(310)
10M	6M	UH-WMR-10MX6M	1.0		1.0		0.75	19.1	0.25	6.4	0.41	10.7	3500(240)
12M	6M	UH-WMR-12MX6M	1.0		1.0		0.75	19.1	0.25	6.4	0.41	10.7	2900(200)
12M	8M	UH-WMR-12MX8M	1.0		1.0		0.75	19.1	0.25	6.4	0.41	10.7	2900(200)

Long Elbow

WL

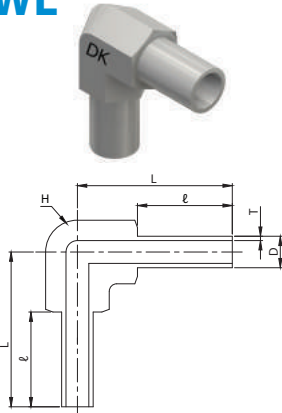

Tube Size (D)	Part No.	Thickness (Tube Wall)		L		ℓ		H Body Cube	Working Pressure
		in.	mm	in.	mm	in.	mm		
1/4	UH-WL-4-191	0.035	0.8	1.23	31.2	0.75	19.1	7/16	5100(351)
3/8	UH-WL-6-191	0.035	0.8	1.20	30.5	0.75	19.1	7/16	3300(227)
1/2	UH-WL-8-191	0.049	1.2	1.34	34.0	0.75	19.1	11/16	3700(254)
3/4	UH-WL-12-191	0.049	1.2	1.46	37.1	0.75	19.1	15/16	2400(165)
1	UH-WL-16-244	0.065	1.6	1.85	47.0	0.94	24.4	1 1/4	2400(165)
Metric	Part No.	mm		in.	mm	in.	mm	in.	psig(bar)
6M	UH-WL-6M-191	1.0		1.23	31.2	0.75	19.1	7/16	6100(420)
8M	UH-WL-8M-191	1.0		1.23	31.2	0.75	19.1	7/16	4500(310)
10M	UH-WL-10M-191	1.0		1.34	34.0	0.75	19.1	11/16	3500(240)
12M	UH-WL-12M-191	1.0		1.34	34.0	0.75	19.1	11/16	2900(200)
18M	UH-WL-18M-191	1.5		1.48	37.6	0.75	19.1	15/16	2900(200)

Long Tee

WT

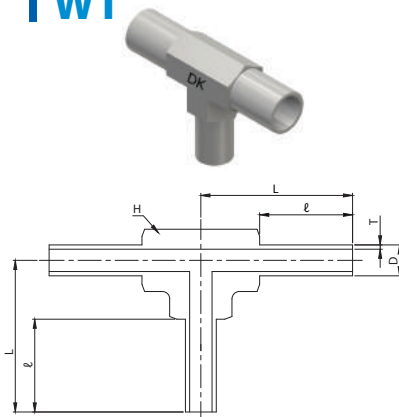

Tube Size (D)	Part No.	Thickness (Tube Wall)		L		ℓ		H Body Cube	Working Pressure
		in.	mm	in.	mm	in.	mm		
1/4	UH-WT-4-191	0.035	0.8	1.23	31.2	0.75	19.1	7/16	5100(351)
3/8	UH-WT-6-191	0.035	0.8	1.20	30.5	0.75	19.1	7/16	3300(227)
1/2	UH-WT-8-191	0.049	1.2	1.34	34.0	0.75	19.1	11/16	3700(254)
3/4	UH-WT-12-191	0.049	1.2	1.46	37.1	0.75	19.1	15/16	2400(165)
1	UH-WT-16-244	0.065	1.6	1.85	47.0	0.94	24.4	1 1/4	2400(165)
Metric	Part No.	mm		in.	mm	in.	mm	in.	psig(bar)
6M	UH-WT-6M-191	1.0		1.23	31.2	0.75	19.1	7/16	6100(420)
8M	UH-WT-8M-191	1.0		1.23	31.2	0.75	19.1	7/16	4500(310)
10M	UH-WT-10M-191	1.0		1.34	34.0	0.75	19.1	11/16	3500(240)
12M	UH-WT-12M-191	1.0		1.34	34.0	0.75	19.1	11/16	2900(200)
18M	UH-WT-18M-191	1.5		1.48	37.6	0.75	19.1	15/16	2900(200)

Long Reducing Tee

WRT

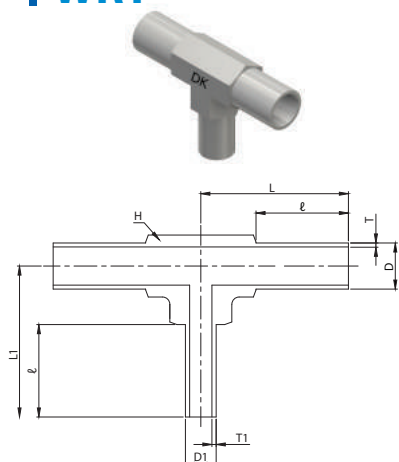

Size (D)	Size (D1)	Part No.	Thickness(Wall) T		Thickness(Wall) T1		L		L1		ℓ		H Body Cube	Working Pressure
			in.	mm	in.	mm	in.	mm	in.	mm	in.	mm		
3/8	1/4	UH-WRT-6X4-191	0.035	0.8	0.035	0.8	1.20	30.5	1.23	31.2	0.75	19.1	7/16	3300(227)
1/2	1/4	UH-WRT-8X4-191	0.049	1.2	0.035	0.8	1.34	34.0	1.34	34.0	0.75	19.1	11/16	3700(254)
1/2	3/8	UH-WRT-8X6-191	0.049	1.2	0.035	0.8	1.34	34.0	1.35	34.3	0.75	19.1	11/16	3300(227)
3/4	1/4	UH-WRT-12X4-191	0.049	1.2	0.035	0.8	1.46	37.1	1.48	37.6	0.75	19.1	15/16	2400(165)
3/4	3/8	UH-WRT-12X6-191	0.049	1.2	0.035	0.8	1.46	37.1	1.48	37.6	0.75	19.1	15/16	2400(165)
Metric	Part No.	mm		mm		in.	mm	in.	mm	in.	mm	in.	mm	psig(bar)
8M	6M	UH-WRT-8MX6M-191		1.0		1.23	31.2	1.23	31.2	0.75	19.1	7/16	4500(310)	
10M	6M	UH-WRT-10MX6M-191		1.0		1.34	34.0	1.34	34.0	0.75	19.1	11/16	3500(240)	
10M	8M	UH-WRT-10MX8M-191		1.0		1.34	34.0	1.34	34.0	0.75	19.1	11/16	2900(200)	
12M	6M	UH-WRT-12MX6M-191		1.0		1.34	34.0	1.34	34.0	0.75	19.1	11/16	2900(200)	
12M	8M	UH-WRT-12MX8M-191		1.0		1.34	34.0	1.34	34.0	0.75	19.1	11/16	2900(200)	

## Long Cross Tee

### WX

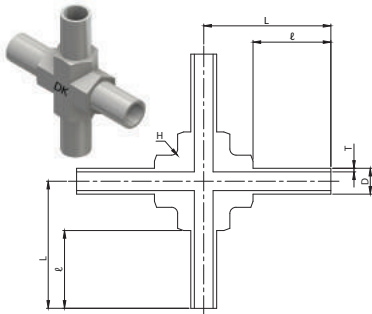

Tube Size (D)	Part No.	Thickness (Tube Wall)		L		ℓ		H Body Cube	Working Pressure
		in.	mm	in.	mm	in.	mm		
1/4	UH-WX-4-191	0.035	0.8	1.23	31.2	0.75	19.1	7/16	5100(351)
3/8	UH-WX-6-191	0.035	0.8	1.20	30.5	0.75	19.1	7/16	3300(227)
1/2	UH-WX-8-191	0.049	1.2	1.31	33.2	0.75	19.1	5/8	3700(254)
Metric	Part No.	mm		in.	mm	in.	mm	in.	psig(bar)
6M	UH-WX-6M-191	1.0		1.23	31.2	0.75	19.1	7/16	6100(420)
8M	UH-WX-8M-191	1.0		1.23	31.2	0.75	19.1	7/16	4500(310)
10M	UH-WX-10M-191	1.0		1.28	32.4	0.75	19.1	5/8	3500(240)
12M	UH-WX-12M-191	1.0		1.28	32.4	0.75	19.1	5/8	2900(200)

## Long Reducer

### WR

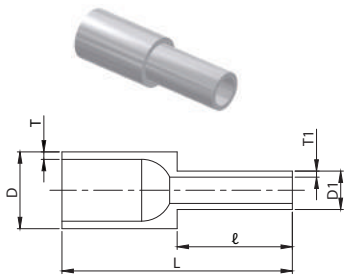

Size (D)	Size (D1)	Part No.	Thickness(Wall) T		Thickness(Wall) T1		L		ℓ		Working Pressure
			in.	mm	in.	mm	in.	mm	in.	mm	
3/8	1/4	UH-WR-6X4-191	0.035	0.8	0.035	0.8	1.5	38.1	0.75	19.1	3300(227)
1/2	1/4	UH-WR-8X4-191	0.049	1.2	0.035	0.8	1.5	38.1	0.75	19.1	3700(254)
1/2	3/8	UH-WR-8X6-191	0.049	1.2	0.035	0.8	1.5	38.1	0.75	19.1	3300(227)
3/4	1/2	UH-WR-12X8-191	0.049	1.2	0.049	1.2	1.5	38.1	0.75	19.1	2400(165)
1	1/2	UH-WR-16X8-191	0.065	1.6	0.049	1.2	1.5	38.1	0.75	19.1	2400(165)
1	3/4	UH-WR-16X12-191	0.065	1.6	0.049	1.2	1.5	38.1	0.75	19.1	2400(165)
Metric		Part No.	mm		mm		in.	mm	in.	mm	psig(bar)
10M	6M	UH-WR-10MX6M-191	1.0		1.0		1.5	38.1	0.75	19.1	3500(240)
10M	8M	UH-WR-10MX8M-191	1.0		1.0		1.5	38.1	0.75	19.1	3500(240)
12M	6M	UH-WR-12MX6M-191	1.0		1.0		1.5	38.1	0.75	19.1	2900(200)
12M	8M	UH-WR-12MX8M-191	1.0		1.0		1.5	38.1	0.75	19.1	2900(200)
12M	10M	UH-WR-12MX10M-191	1.0		1.0		1.5	38.1	0.75	19.1	2900(200)
18M	6M	UH-WR-18MX6M-191	1.5		1.0		1.5	38.1	0.75	19.1	2900(200)
18M	12M	UH-WR-18MX12M-191	1.5		1.0		1.5	38.1	0.75	19.1	2900(200)

## Auto Butt Weld Long Elbow

### WLA

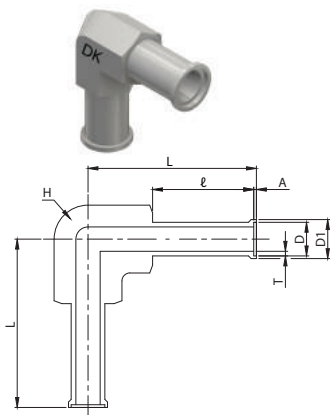

Size (D)	Part No.	Thickness (Tube Wall)		L		ℓ		A		D1		H Body Cube	Working Pressure
		in.	mm	in.	mm	in.	mm	in.	mm	in.	mm		
1/4	UH-WLA-4-191	0.035	0.8	1.25	31.8	0.75	19.1	0.02	0.51	0.29	7.4	7/16	5100(351)
3/8	UH-WLA-6-191	0.035	0.8	1.23	31.2	0.75	19.1	0.03	0.76	0.41	10.4	7/16	3300(227)
1/2	UH-WLA-8-191	0.049	1.2	1.38	35.1	0.75	19.1	0.04	1.0	0.55	14.0	11/16	3700(254)
3/4	UH-WLA-12-191	0.049	1.2	1.50	38.1	0.75	19.1	0.04	1.0	0.80	20.3	15/16	2400(165)
1	UH-WLA-16-244	0.065	1.6	1.89	48.0	0.94	24.4	0.04	1.0	1.06	26.9	1 1/4	2400(165)
Metric	Part No.	mm		in.	mm	in.	mm	in.	mm	in.	mm	in.	psig(bar)
6M	UH-WLA-6M-191	1.0		1.25	31.8	0.75	19.1	0.02	0.51	0.27	6.9	7/16	6100(420)
8M	UH-WLA-8M-191	1.0		1.26	32.0	0.75	19.1	0.03	0.76	0.35	8.9	7/16	4500(310)
10M	UH-WLA-10M-191	1.0		1.37	34.8	0.75	19.1	0.03	0.76	0.43	10.9	11/16	3500(240)
12M	UH-WLA-12M-191	1.0		1.38	35.1	0.75	19.1	0.04	1.0	0.52	13.2	11/16	2900(200)
18M	UH-WLA-18M-191	1.5		1.52	38.6	0.75	19.1	0.04	1.0	0.76	19.3	15/16	2900(200)

Auto Butt Weld Long Tee

**WTA**

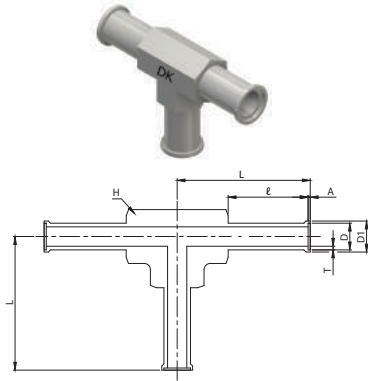

Size (D)	Part No.	Thickness (Tube Wall)		L		ℓ		A		D1		H Body Cube	Working Pressure
		in.	mm	in.	mm	in.	mm	in.	mm	in.	mm		
1/4	UH-WTA-4-191	0.035	0.8	1.25	31.8	0.75	19.1	0.02	0.51	0.29	7.4	7/16	5100(351)
3/8	UH-WTA-6-191	0.035	0.8	1.23	31.2	0.75	19.1	0.03	0.76	0.41	10.4	7/16	3300(227)
1/2	UH-WTA-8-191	0.049	1.2	1.38	35.1	0.75	19.1	0.04	1.0	0.55	14.0	11/16	3700(254)
3/4	UH-WTA-12-191	0.049	1.2	1.50	38.1	0.75	19.1	0.04	1.0	0.80	20.3	15/16	2400(165)
1	UH-WTA-16-244	0.065	1.6	1.89	48.0	0.94	24.4	0.04	1.0	1.06	26.9	1 1/4	2400(165)
Metric	Part No.	mm		in.	mm	in.	mm	in.	mm	in.	mm	in.	psig(bar)
6M	UH-WTA-6M-191	1.0	1.25	31.8	0.75	19.1	0.02	0.51	0.27	6.8	7/16	6100(420)	
8M	UH-WTA-8M-191	1.0	1.26	32.0	0.75	19.1	0.03	0.76	0.35	8.9	7/16	4500(310)	
10M	UH-WTA-10M-191	1.0	1.37	34.8	0.75	19.1	0.03	0.76	0.43	10.9	11/16	3500(240)	
12M	UH-WTA-12M-191	1.0	1.38	35.1	0.75	19.1	0.04	1.0	0.52	13.2	11/16	2900(200)	
18M	UH-WTA-18M-191	1.5	1.52	38.6	0.75	19.1	0.04	1.0	0.76	19.3	15/16	2900(200)	

Auto Butt Weld Long Cross Tee

**WXA**

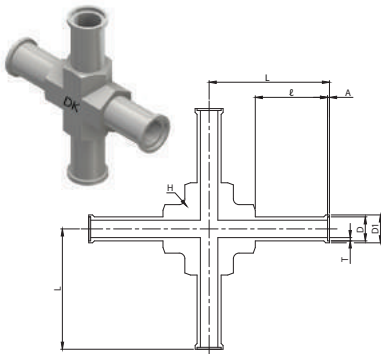

Size (D)	Part No.	Thickness (Tube Wall)		L		ℓ		A		D1		H Body Cube	Working Pressure
		in.	mm	in.	mm	in.	mm	in.	mm	in.	mm		
1/4	UH-WXA-4-191	0.035	0.8	1.25	31.8	0.75	19.1	0.02	0.51	0.29	7.4	7/16	5100(351)
3/8	UH-WXA-6-191	0.035	0.8	1.23	31.2	0.75	19.1	0.03	0.76	0.41	10.4	7/16	3300(227)
1/2	UH-WXA-8-191	0.049	1.2	1.35	34.3	0.75	19.1	0.04	1.0	0.55	14.0	5/8	3700(254)
Metric	Part No.	mm		in.	mm	in.	mm	in.	mm	in.	mm	in.	psig(bar)
6M	UH-WXA-6M-191	1.0	1.25	31.8	0.75	19.1	0.02	0.51	0.27	6.8	7/16	6100(420)	
8M	UH-WXA-8M-191	1.0	1.25	31.8	0.75	19.1	0.03	0.76	0.35	8.9	7/16	4500(310)	
10M	UH-WXA-10M-191	1.0	1.23	31.2	0.75	19.1	0.03	0.76	0.43	10.9	5/8	3500(240)	
12M	UH-WXA-12M-191	1.0	1.34	34.0	0.75	19.1	0.04	1.0	0.52	13.2	5/8	2900(200)	

Auto Butt Weld Long Reducing Tee

**WRTA**

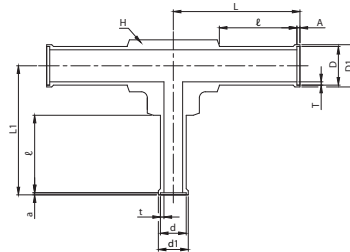

Size (D)	Size (d)	Part No.	Thickness(Wall) T		Thickness(Wall) t		L		L1		ℓ		D1		d1		A		a		H Body Cube	Working Pressure	
			in.	mm	in.	mm	in.	mm	in.	mm	in.	mm	in.	mm	in.	mm	in.	mm	in.	mm			
3/8	1/4	UH-WRTA-6X4-191	0.035	0.8	0.035	0.8	1.23	31.2	1.25	31.8	0.75	19.10	0.41	10.4	0.29	7.4	0.03	0.76	0.02	0.51	7/16	3300(227)	
1/2	1/4	UH-WRTA-8X4-191	0.049	1.2	0.035	0.8	1.38	35.1	1.38	35.1	0.75	19.10	0.55	14.0	0.29	7.4	0.04	1.0	0.02	0.51	11/16	3700(254)	
1/2	3/8	UH-WRTA-8X6-191	0.049	1.2	0.035	0.8	1.38	35.1	1.37	34.8	0.75	19.10	0.55	14.0	0.41	10.4	0.04	1.0	0.03	0.76	11/16	3300(227)	
3/4	3/8	UH-WRTA-12X6-191	0.049	1.2	0.035	0.8	1.50	38.1	1.50	38.1	0.75	19.10	0.80	20.3	0.41	10.4	0.04	1.0	0.03	0.76	15/16	2400(165)	
3/4	1/2	UH-WRTA-12X8-191	0.049	1.2	0.049	1.2	1.50	38.1	1.50	38.1	0.75	19.10	0.80	20.3	0.55	14.0	0.04	1.0	0.04	1.0	15/16	2400(165)	
Metric	Part No.	mm		mm		in.	mm	in.	mm	in.	mm	in.	mm	in.	mm	in.	mm	in.	mm	in.	mm	in.	psig(bar)
12M	6M	UH-WRTA-12MX6M-191	1.0	1.0	1.38	35.1	1.36	34.5	0.75	19.10	0.52	13.2	0.27	6.8	0.02	0.51	0.02	0.51	11/16	2900(200)			

## Auto Butt Weld Union

### WUA

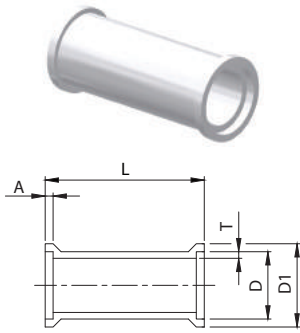

Tube Size (D)	Part No.	Thickness (Tube Wall)		L		A		D1		Working Pressure psig(bar)
		in.	mm	in.	mm	in.	mm	in.	mm	
1/4	UH-WUA-4	0.035	0.8	1.0	25.4	0.02	0.51	0.29	7.4	5100(351)
3/8	UH-WUA-6	0.035	0.8	1.0	25.4	0.03	0.76	0.41	10.4	3300(227)
1/2	UH-WUA-8	0.049	1.2	1.0	25.4	0.04	1.0	0.55	14.0	3700(254)
3/4	UH-WUA-12	0.049	1.2	1.0	25.4	0.04	1.0	0.80	20.3	2400(165)
1	UH-WUA-16	0.065	1.6	1.25	31.8	0.04	1.0	1.06	26.9	2400(165)
Metric	Part No.	mm		in.	mm	in.	mm	in.	mm	psig(bar)
6M	UH-WUA-6M	1.0		1.25	31.8	0.02	0.51	0.27	6.8	6100(420)
8M	UH-WUA-8M	1.0		1.25	31.8	0.03	0.76	0.35	8.9	4500(310)
10M	UH-WUA-10M	1.0		1.25	31.8	0.03	0.76	0.43	10.9	3500(240)
12M	UH-WUA-12M	1.0		1.25	31.8	0.04	1.0	0.52	13.2	2900(200)
18M	UH-WUA-18M	1.5		1.25	31.8	0.04	1.0	0.76	19.3	2900(200)

## Auto Butt Weld Reducing Union

### WRUA

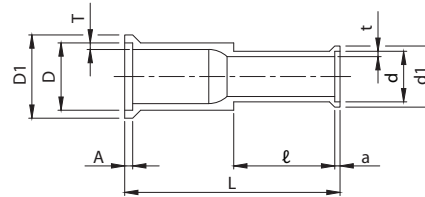

Size (D)	Size (d)	Part No.	Thickness(Wall) T		Thickness(Wall) t		L		l		D1		d1		A		a		Working Pressure psig(bar)
			in.	mm	in.	mm	in.	mm	in.	mm	in.	mm	in.	mm	in.	mm	in.	mm	
3/8	1/4	UH-WRUA-6x4-191	0.035	0.8	0.035	0.8	1.58	40.1	0.75	19.1	0.41	10.4	0.29	7.4	0.03	0.76	0.02	0.51	3300(227)
1/2	1/4	UH-WRUA-8x4-191	0.049	1.2	0.035	0.8	1.58	40.1	0.75	19.1	0.55	14.0	0.29	7.4	0.04	1.0	0.02	0.51	3700(254)
1/2	3/8	UH-WRUA-8x6-191	0.049	1.2	0.035	0.8	1.58	40.1	0.75	19.1	0.55	14.0	0.41	10.4	0.04	1.0	0.03	0.76	3300(227)
3/4	1/2	UH-WRUA-12x8-191	0.049	1.2	0.049	1.2	1.62	41.1	0.75	19.1	0.80	20.3	0.55	14.0	0.04	1.0	0.04	1.0	2400(165)
Metric		Part No.	mm		mm		in.	mm	in.	mm	in.	mm	in.	mm	in.	mm	in.	mm	psig(bar)
8M	6M	UH-WRUA-8Mx6M-191	1.0		1.0		1.57	39.9	0.75	19.1	0.35	8.9	0.27	6.9	0.03	0.76	0.02	0.51	4500(310)
12M	6M	UH-WRUA-12Mx6M-191	1.0		1.0		1.58	40.1	0.75	19.1	0.52	13.2	0.27	6.9	0.04	1.0	0.02	0.51	2900(200)
12M	8M	UH-WRUA-12Mx8M-191	1.0		1.0		1.59	40.4	0.75	19.1	0.52	13.2	0.35	8.9	0.04	1.0	0.03	0.76	2900(200)

## Pressure Rating

All pressure rating follow the calculation as to ASME B31.3 Process Piping code and ASME B31.1 Power Piping code.

The working pressure rating at the room temperature is determined by the material of gasket and the allowable temperature range per the materials is listed in Table 2.

Table 2. Temperature range

Part	Material	Temperature °F (°C)
Fitting	316L Stainless Steel	1000 (537)
	316L Stainless Steel VAR	
Gasket	316L Stainless Steel	1000 (537)
	Nickel	600 (315)

## Material

Material	Designation	Specification	
		Bar stock	Forging
316L Stainless Steel	SL	ASME SA479	ASME SA182
316L Stainless Steel VAR	DL	ASTM A479/A276	ASTM A182
Gasket	316L Stainless Steel	ASTM A167	
	Nickel	ASTM B162	

## Feature

- Leak-tight service provided from vacuum to positive pressure application
- Minimized space is needed for installation and or removal

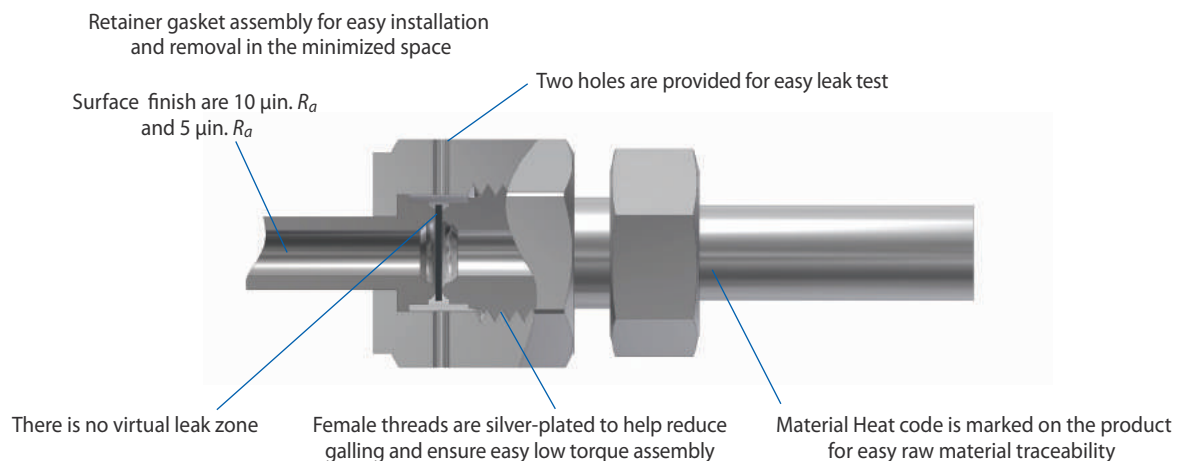

## Cleaning & Packing

Passivation is done in accordance with ASTM A380, Ultra-sonic cleaning is performed in a class 100 environment with resistivity over 18MΩ D.I water after finishing the passivation for precision cleaning.

After cleaning, all product is double packed in the clean room using anti-static polyethylene bags where high purity nitrogen inclusion.

## Surface Roughness

Grade	Designation	Surface Level	
BA	B	$R_a$ : 10µin	$R_y$ : 3.0µm
EP	P	$R_a$ : 5µin	$R_y$ : 0.7µm

## Plating

The internal surface of the female-threaded nut are silver plated to help reduce galling and reduces the pull-up torque.

Note : In the event of the damage or removal of the silver plating, thread galling may occur damaging the fitting components and preventing against proper sealing performance.

## Testing

DCR Fittings are rated to a helium leak rate of less than  $1 \times 10^{-9}$  mbar.l/sec and tested in accordance with SEMI F1-96 and SEMA-90120391B-STD.

## Metal Gasket Face-Seal Fittings

Short Gland

**SG**

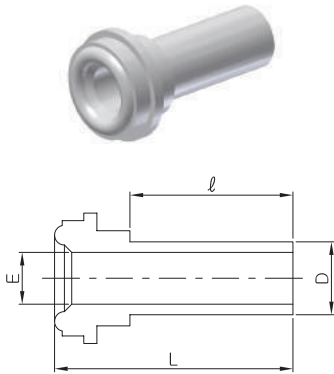

Part No.	Head Size (in.)	Tube Size (D)		L		ℓ		E		Working Pressure psig(bar)
		in.	mm	in.	mm	in.	mm	in.	mm	
UH-SG-2-191	1/8	1/8	3.17	1.08	27.40	0.75	19.1	0.06	1.5	8500(585)
UH-SG-4-64	1/4	1/4	6.35	0.6	15.20	0.25	6.4	0.18	4.6	5100(350)
UH-SG-4-96	1/4	1/4	6.35	0.72	18.30	0.38	9.6	0.18	4.6	5100(350)
UH-SG-4-191	1/4	1/4	6.35	1.1	27.95	0.75	19.1	0.18	4.6	5100(350)
UH-SG-6-64	1/2	3/8	9.53	0.62	15.80	0.25	6.4	0.31	7.9	3300(227)
UH-SG-6-191	1/2	3/8	9.53	1.12	28.50	0.75	19.1	0.31	7.9	3300(227)
UH-SG-8-64	1/2	1/2	12.7	0.62	15.80	0.25	6.4	0.40	10.2	3500(241)
UH-SG-8-96	1/2	1/2	12.7	0.74	18.80	0.38	9.6	0.40	10.2	3500(241)
UH-SG-8-191	1/2	1/2	12.7	1.12	28.50	0.75	19.1	0.40	10.2	3500(241)
UH-SG-8X4-191	1/2	1/4	6.35	1.12	28.50	0.75	19.1	0.18	4.6	4300(296)
<b>Metric</b>	<b>in.</b>	<b>mm</b>	<b>in.</b>	<b>mm</b>	<b>in.</b>	<b>mm</b>	<b>mm</b>	<b>mm</b>	<b>psig(bar)</b>	
UH-SG-4X6M-191	1/4	6.0	1.16	29.5	0.75	19.1	4.0	6800(468)		
UH-SG-4X8M-191	1/4	8.0	1.16	29.5	0.75	19.1	6.0	4900(337)		
UH-SG-8X10M-191	1/2	10.0	1.16	29.5	0.75	19.1	8.0	3500(241)		
UH-SG-8X12M-191	1/2	12.0	1.16	29.5	0.75	19.1	10.0	3100(213)		
UH-SG-12X18M-191	3/4	18.0	1.22	31.0	0.75	19.1	15.0	3000(206)		

Long Gland

**LG**

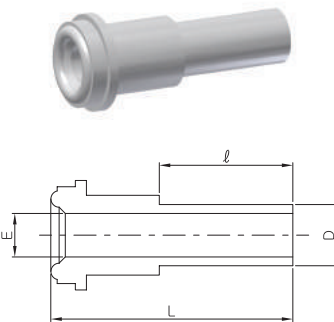

Part No.	Head Size (in.)	Tube Size (D)		L		ℓ		E		Working Pressure psig(bar)
		in.	mm	in.	mm	in.	mm	in.	mm	
UH-LG-2-191	1/8	1/8	3.17	1.42	36.1	0.75	19.1	0.06	1.5	8500(585)
UH-LG-4-64	1/4	1/4	6.35	1.20	30.5	0.25	6.4	0.18	4.6	5100(350)
UH-LG-4-91	1/4	1/4	6.35	1.31	33.3	0.36	9.1	0.18	4.6	5100(349)
UH-LG-4-96	1/4	1/4	6.35	1.32	33.5	0.38	9.6	0.18	4.6	5100(350)
UH-LG-4-191	1/4	1/4	6.35	1.70	43.2	0.75	19.1	0.18	4.6	5100(350)
UH-LG-6-64	1/2	3/8	9.53	1.29	32.8	0.25	6.4	0.31	7.9	3300(227)
UH-LG-6-191	1/2	3/8	9.53	1.79	45.5	0.75	19.1	0.31	7.9	3300(227)
UH-LG-8-64	1/2	1/2	12.7	1.29	32.8	0.25	6.4	0.40	10.2	3500(241)
UH-LG-8-96	1/2	1/2	12.7	1.41	35.8	0.38	9.6	0.40	10.2	3500(241)
UH-LG-8-191	1/2	1/2	12.7	1.79	45.5	0.75	19.1	0.40	10.2	3500(241)
UH-LG-8X4-191	1/2	1/4	6.35	1.80	45.7	0.75	19.1	0.18	4.6	4300(296)
UH-LG-12-191	3/4	3/4	19.05	2.03	51.6	0.75	19.1	0.65	16.5	2400(165)
UH-LG-16-191	1	1	25.4	2.32	58.9	0.75	19.1	0.87	22.1	2400(165)
<b>Metric</b>	<b>in.</b>	<b>mm</b>	<b>in.</b>	<b>mm</b>	<b>in.</b>	<b>mm</b>	<b>mm</b>	<b>mm</b>	<b>psig(bar)</b>	
UH-LG-4X6M-191	1/4	6.0	1.70	43.2	0.75	19.1	4.0	6800(468)		
UH-LG-4X8M-191	1/4	8.0	1.70	43.2	0.75	19.1	6.0	4900(337)		
UH-LG-8X10M-191	1/2	10.0	1.79	45.5	0.75	19.1	8.0	3500(241)		
UH-LG-8X12M-191	1/2	12.0	1.79	45.5	0.75	19.1	10.0	3100(213)		
UH-LG-12X18M-191	3/4	18.0	2.03	51.6	0.75	19.1	15.0	3000(206)		

Auto Butt Weld Short Gland

**SGA**

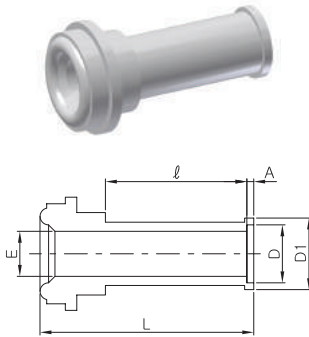

Part No.	Tube Size (D)		Head Size (in.)	D1		E		A		L		ℓ		Working Pressure psig(bar)
	in.	mm		in.	mm	in.	mm	in.	mm	in.	mm	in.	mm	
UH-SGA-4-64	1/4	6.35	1/4	0.29	7.4	0.18	4.6	0.02	0.5	0.62	15.7	0.25	6.4	5100(351)
UH-SGA-4-191	1/4	6.35	1/4	0.29	7.4	0.18	4.6	0.02	0.5	1.12	28.4	0.75	19.1	5100(351)
UH-SGA-6-64	3/8	9.53	1/2	0.41	10.4	0.31	7.9	0.03	0.8	0.65	16.6	0.25	6.4	3300(227)
UH-SGA-6-191	3/8	9.53	1/2	0.41	10.4	0.31	7.9	0.03	0.8	1.15	29.2	0.75	19.1	3300(227)
UH-SGA-8-64	1/2	12.7	1/2	0.55	14.0	0.40	10.2	0.04	1.0	0.66	16.8	0.25	6.4	3500(241)
UH-SGA-8-191	1/2	12.7	1/2	0.55	14.0	0.40	10.2	0.04	1.0	1.16	29.5	0.75	19.1	3500(241)
Metric	mm	in.	in.	mm	mm	in.	mm	in.	mm	in.	mm	in.	mm	psig(bar)
UH-SGA-6M-191	6.0	1/4	0.27	6.8	4.0	0.02	0.5	1.18	30.0	0.75	19.1	6800(468)		
UH-SGA-8M-191	8.0	1/4	0.35	8.9	6.0	0.03	0.8	1.19	30.2	0.75	19.1	4900(337)		
UH-SGA-10M-191	10.0	1/2	0.43	10.9	8.0	0.03	0.8	1.22	31.0	0.75	19.1	3500(241)		
UH-SGA-12M-191	12.0	1/2	0.52	13.2	10.0	0.04	1.0	1.20	30.5	0.75	19.1	3100(213)		

Auto Butt Weld Long Gland

**LGA**

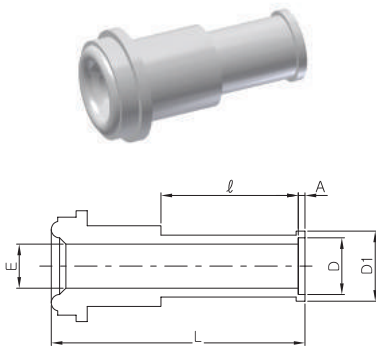

Part No.	Head Size (in.)	Tube Size (D)		D1		E		A		L		ℓ		Working Pressure psig(bar)
		in.	mm	in.	mm	in.	mm	in.	mm	in.	mm	in.	mm	
UH-LGA-4-191	1/4	1/4	6.35	0.29	7.4	0.18	4.6	0.02	0.5	1.72	43.7	0.75	19.1	5100(351)
UH-LGA-8X4-191	1/2	1/4	6.35	0.29	7.4	0.18	4.6	0.02	0.5	1.82	46.2	0.75	19.1	3500(241)
UH-LGA-6-191	1/2	3/8	9.53	0.41	10.4	0.31	7.9	0.03	0.8	1.82	46.2	0.75	19.1	3300(227)
UH-LGA-8-191	1/2	1/2	12.7	0.55	14.0	0.40	10.2	0.04	1.0	1.83	46.5	0.75	19.1	3500(241)
UH-LGA-12-191	3/4	3/4	19.05	0.8	20.3	0.65	16.5	0.04	1.0	2.07	52.6	0.75	19.1	2400(165)
UH-LGA-16-244	1	1	25.4	1.06	26.9	0.87	22.1	0.04	1.0	2.57	65.3	0.96	24.4	2400(165)
Metric	in.	mm	in.	mm	mm	in.	mm	in.	mm	in.	mm	in.	mm	psig(bar)
UH-LGA-6M-191	1/4	6.0	0.27	6.8	4.0	0.02	0.5	1.72	43.7	0.75	19.1	6800(468)		
UH-LGA-8M-191	1/4	8.0	0.35	8.9	6.0	0.03	0.8	1.73	43.9	0.75	19.1	4900(337)		
UH-LGA-10M-191	1/2	10.0	0.43	10.9	8.0	0.03	0.8	1.83	46.5	0.75	19.1	3500(241)		
UH-LGA-12M-191	1/2	12.0	0.52	13.2	10.0	0.04	1.0	1.83	46.5	0.75	19.1	3100(213)		
UH-LGA-18M-191	3/4	18.0	0.76	19.3	15.0	0.04	1.0	2.07	52.6	0.75	19.1	3000(206)		

## Male Gland

### GM

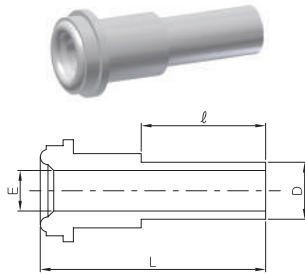

Part No.	Head Size (in.)	Tube Size (D)		E		L		ℓ		Working Pressure psig(bar)
		in.	mm	in.	mm	in.	mm	in.	mm	
UH-GM-2	1/8	1/8	3.17	0.06	1.5	0.70	17.8	0.28	7.1	11200(771)
UH-GM-4X2	1/4	1/8	3.17	0.06	1.5	1.31	33.3	0.28	7.1	10000(689)
UH-GM-4	1/4	1/4	6.35	0.12	3.0	1.31	33.3	0.41	10.4	10000(689)
UH-GM-6	1/2	3/8	9.53	0.28	7.1	1.50	38.1	0.41	10.4	4300(296)
UH-GM-8	1/2	1/2	12.7	0.4	10.2	1.50	38.1	0.50	12.7	3500(241)
UH-GM-8X4	1/2	1/4	6.35	0.12	3.0	1.50	38.1	0.41	10.4	4300(296)
UH-GM-12	3/4	3/4	19.05	0.53	13.5	2.00	50.8	0.62	15.7	3700(254)
UH-GM-16	1	1	25.4	0.75	19.1	2.22	56.4	0.81	20.6	3000(206)

## Socket Weld Long Gland

### GSL

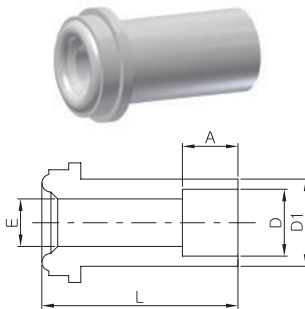

Part No.	Tube Size (D)		Head Size (in.)	D1		E		L		A		Working Pressure psig(bar)
	in.	mm		in.	mm	in.	mm	in.	mm	in.	mm	
UH-GSL-2	1/8	3.17	1/8	0.20	5.1	0.09	2.3	0.70	17.8	0.10	2.5	7100(489)
UH-GSL-4	1/4	6.35	1/4	0.35	8.9	0.18	4.6	1.31	33.3	0.28	7.1	5500(378)
UH-GSL-6	3/8	9.53	1/2	0.60	15.2	0.28	7.1	1.50	38.1	0.31	7.9	4300(291)
UH-GSL-8	1/2	12.7	1/2	0.60	15.2	0.40	10.2	1.50	38.1	0.38	9.6	3000(206)
UH-GSL-12	3/4	19.05	3/4	0.88	22.4	0.62	15.7	2.00	50.8	0.44	11.2	2800(192)
UH-GSL-16	1	25.4	1	1.19	30.2	0.87	22.1	2.22	56.4	0.62	15.7	3000(206)

## Socket Weld Reducing Long Gland

### GSR

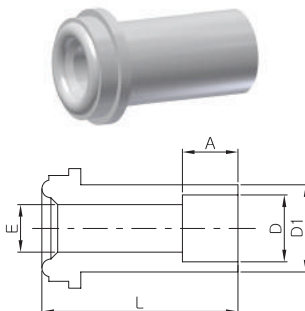

Part No.	Head Size (in.)	Tube Size (D)		D1		E		L		A		Working Pressure psig(bar)
		in.	mm	in.	mm	in.	mm	in.	mm	in.	mm	
UH-GSR-4X2	1/4	1/8	3.17	0.35	8.9	0.09	2.3	1.31	33.3	0.10	2.5	8000(551)
UH-GSR-8X4	1/2	1/4	6.35	0.60	15.2	0.18	4.6	1.50	38.1	0.28	7.1	3500(241)

Socket Weld Short Gland

GSS

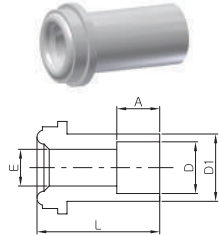

Part No.	Tube Size (D)		Head Size (in.)	D1		E		L		A		Working Pressure psig(bar)
	in.	mm		in.	mm	in.	mm	in.	mm	in.	mm	
UH-GSS-4	1/4	6.35	1/4	0.35	8.9	0.18	4.6	0.50	12.7	0.28	7.1	5500(378)
UH-GSS-4-19								0.75	19.1			

Tube Adapter Gland

GT

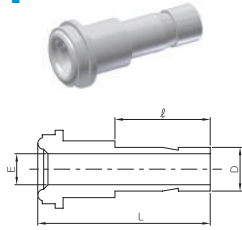

Part No.	Tube Size (D)		Head Size (in.)	E		L		l		Working Pressure psig(bar)
	in.	mm		in.	mm	in.	mm	in.	mm	
UH-GT-4	1/4	6.35	1/4	0.17	4.3	1.62	41.0	0.64	16.2	10000
UH-GT-6	3/8	9.53	1/2	0.27	6.8	1.81	46.0	0.70	17.8	4300
UH-GT-8	1/2	12.7		0.37	9.4	1.94	49.3	0.96	24.4	4300

Blind Gland

BG

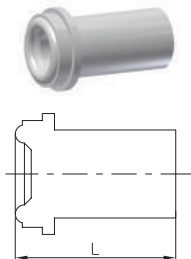

Part No.	Tube Size (D)		Head Size (in.)	L	
	in.	mm		in.	mm
UH-BG-2	1/8	3.17	1/8	0.70	17.8
UH-BG-4	1/4	6.35	1/4	1.31	33.3
UH-BG-8	1/2	12.7	1/2	1.50	38.1
UH-BG-12	3/4	19.05	3/4	2.00	50.8
UH-BG-16	1	25.4	1	2.22	56.4

Female Nut

FN

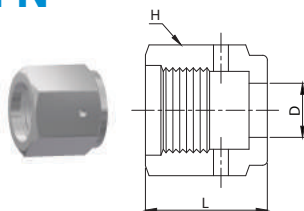

Part No.	Size (in.)	L		D		H Hex (in.)
		in.	mm	in.	mm	
U-FN-2	1/8	0.53	13.5	0.21	5.3	7/6
U-FN-4	1/4	0.81	20.6	0.36	9.1	3/4
U-FN-8	1/2	0.88	22.4	0.61	15.5	1 1/16
U-FN-12	3/4	1.12	28.4	0.89	22.6	1 1/2
U-FN-16	1	1.34	34.0	1.20	30.5	1 3/4

## Male Nut

### MN

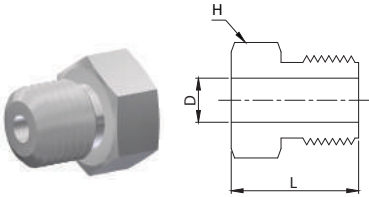

Part No.	Size (in.)	L		D		H Hex (in.)
		in.	mm	in.	mm	
U-MN-2	1/8	0.50	12.7	0.21	5.3	3/8
U-MN-4	1/4	0.71	18.0	0.36	9.1	5/8
U-MN-8	1/2	0.81	20.6	0.61	15.5	15/16
U-MN-12	3/4	1.00	25.4	0.89	22.6	1 5/16
U-MN-16	1	1.19	30.2	1.20	30.5	1 5/8

## Cap

### CP

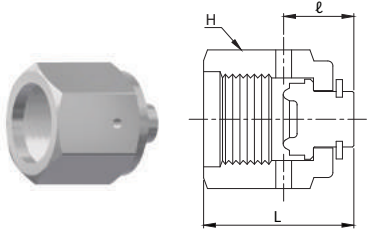

Part No.	Size (in.)	L		ℓ		H Hex (in.)
		in.	mm	in.	mm	
U-CP-2	1/8	0.63	16.0	0.30	7.6	7/16
U-CP-4	1/4	0.94	23.9	0.44	11.2	3/4
U-CP-8	1/2	1.01	25.6	0.45	11.4	1 1/16
U-CP-12	3/4	1.29	32.8	0.54	13.7	1 1/2
U-CP-16	1	1.54	39.1	0.63	16.0	1 3/4

## Plug

### PG

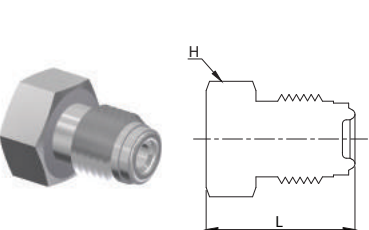

Part No.	Size (in.)	L		H Hex (in.)
		in.	mm	
U-PG-2	1/8	0.68	17.3	3/8
U-PG-4	1/4	0.92	23.4	5/8
U-PG-8	1/2	1.08	27.4	15/16
U-PG-12	3/4	1.43	36.3	1 5/16
U-PG-16	1	1.52	38.6	1 5/8

Gasket

**GK**

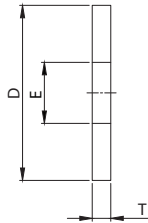

Part No.	Size (in.)	T		D		E	
		in.	mm	in.	mm	in.	mm
U-GK-2	1/8	0.028	0.7	0.26	6.6	0.09	2.3
U-GK-4	1/4	0.028	0.7	0.50	12.7	0.22	5.6
U-GK-8	1/2	0.028	0.7	0.78	19.8	0.44	11.2
U-GK-12	3/4	0.028	0.7	1.14	29.0	0.66	16.7
U-GK-16	1	0.028	0.7	1.40	35.8	1.89	22.6

Gasket Retainer

**GKT**

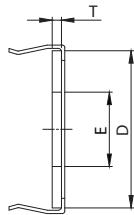

Part No.	Size (in.)	T		D		E	
		in.	mm	in.	mm	in.	mm
U-GKT-4	1/4	0.028	0.7	0.47	11.85	0.22	5.6
U-GKT-8	1/2	0.028	0.7	0.76	19.27	0.44	11.2
U-GKT-12	3/4	0.028	0.7	1.10	27.90	0.66	16.7
U-GKT-16	1	0.028	0.7	1.34	34.20	0.89	22.6

Gasket Blind

**GKB**

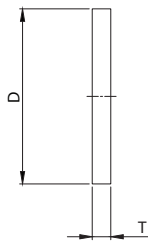

Part No.	Size (in.)	T		D	
		in.	mm	in.	mm
U-GKB-2	1/8	0.028	0.7	0.26	6.6
U-GKB-4	1/4	0.028	0.7	0.50	12.7
U-GKB-8	1/2	0.028	0.7	0.78	19.8
U-GKB-12	3/4	0.028	0.7	1.14	29.0
U-GKB-16	1	0.028	0.7	1.40	35.8

Double Male Union

**MU**

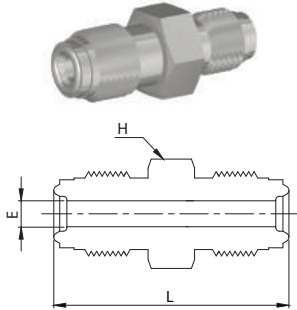

Part No.	Head Size (in.)	L		E		H Hex (in.)
		in.	mm	in.	mm	
UH-MU-2	1/8	1.13	28.7	0.09	2.3	3/8
UH-MU-4	1/4	1.55	39.4	0.18	4.6	5/8
UH-MU-8	1/2	1.84	46.7	0.40	10.2	15/16
UH-MU-12	3/4	2.44	62	0.62	15.7	1 5/16
UH-MU-16	1	2.59	65.8	0.87	22.1	1 5/8

Double Male Reducing Union

**MRU**

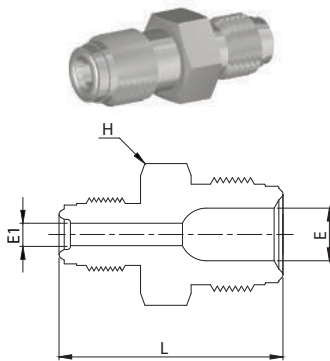

Part No.	Head Size (in.)	Head Size (in.)	L		E		E1		H Hex (in.)
			in.	mm	in.	mm	in.	mm	
UH-MRU-8X4	1/2	1/4	1.71	43.4	0.4	10.2	0.18	4.6	15/16

Bulkhead Union

**BHU**

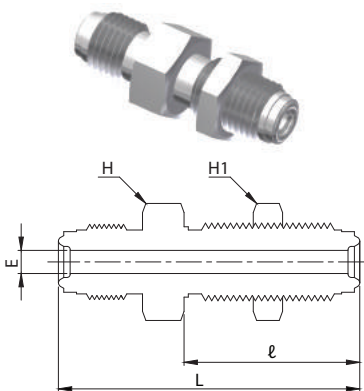

Part No.	Head Size (in.)	L		ℓ		E		H Hex (in.)	H1 Hex (in.)
		in.	mm	in.	mm	in.	mm		
UH-BHU-4	1/4	2.23	56.6	1.30	33.0	0.18	4.6	3/4	3/4
UH-BHU-4-462	1/4	1.82	46.2	0.99	25.1	0.18	4.6	3/4	3/4
UH-BHU-8	1/2	2.57	65.3	1.48	37.6	0.40	10.2	1 1/16	1 1/16
UH-BHU-8-544	1/2	2.14	54.4	1.11	28.2	0.40	10.2	1 1/16	1 1/16

## Metal Gasket Face-Seal Fittings

Tube Fitting Connector

**DC**

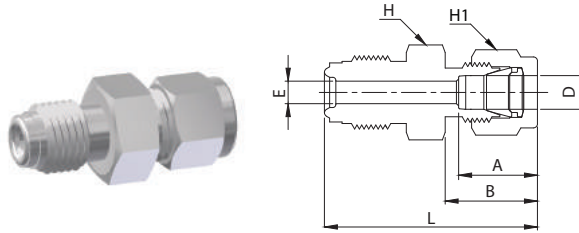

Part No.	Head Size (in.)	Tube Size (D)	L		B		A		E		H Hex (in.)	H1 Hex (in.)
			in.	mm	in.	mm	in.	mm	in.	mm		
UH-DC-4X2	1/4	1/8	1.53	38.9	0.60	15.2	0.5	12.7	0.09	2.3	5/8	7/16
UH-DC-4	1/4	1/4	1.62	41.1	0.70	17.8	0.6	15.2	0.18	4.6	5/8	9/16
UH-DC-8X6	1/2	3/8	1.84	46.7	0.76	19.3	0.66	16.8	0.28	7.1	15/16	11/16
UH-DC-8	1/2	1/2	1.95	49.5	0.86	21.8	0.9	22.9	0.4	10.2	15/16	7/8

Tube Fitting Bulkhead Connector

**DBHC**

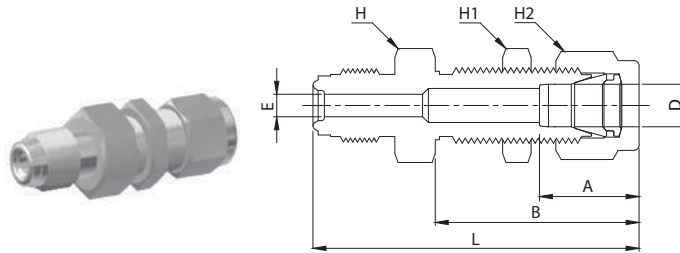

Part No.	Head Size (in.)	Tube Size (D)	L		B		A		E		H Hex (in.)	H1 Hex (in.)	H2 Hex (in.)
			in.	mm	in.	mm	in.	mm	in.	mm			
UH-DBHC-4	1/4	1/4	2.25	57.2	1.32	33.5	0.6	15.2	0.18	4.6	5/8	5/8	9/16
UH-DBHC-4-478	1/4	1/4	1.88	47.8	1.05	26.7	0.6	15.2	0.18	4.6	5/8	5/8	9/16
UH-DBHC-8X6	1/2	3/8	2.54	64.5	1.45	36.8	0.66	16.8	0.28	7.1	15/16	3/4	11/16
UH-DBHC-8	1/2	1/2	2.74	69.6	1.65	41.9	0.9	22.9	0.4	10.2	15/16	15/16	7/8

Male NPT Connector

**MC-N**

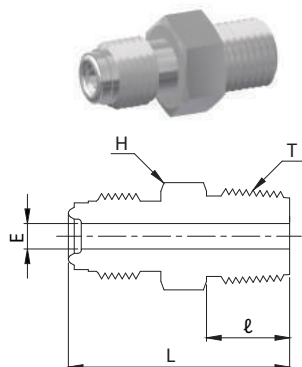

Part No.	Head Size (in.)	Size NPT T	L		ℓ		E		H Hex (in.)
			in.	mm	in.	mm	in.	mm	
UH-MC4-2N	1/4	1/8	1.31	33.3	0.38	9.6	0.18	4.6	5/8
UH-MC4-4N	1/4	1/4	1.49	37.8	0.56	14.2	0.18	4.6	5/8
UH-MC8-4N	1/2	1/4	1.65	41.9	0.56	14.2	0.28	7.1	15/16
UH-MC8-6N	1/2	3/8	1.65	41.9	0.56	14.2	0.38	9.6	15/16
UH-MC8-8N	1/2	1/2	1.84	46.7	0.75	19.1	0.40	10.2	15/16
UH-MC12-12N	3/4	3/4	2.19	55.6	0.75	19.1	0.62	15.7	1 5/16
UH-MC16-16N	1	1	2.47	62.7	0.94	23.9	0.87	22.1	1 5/8

Female NPT Connector

**FC-N**

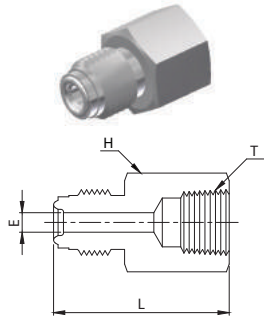

Part No.	Head Size (in.)	Size NPT T	L		E		H Hex (in.)
			in.	mm	in.	mm	
UH-FC4-2N	1/4	1/8	1.41	35.8	0.18	4.6	5/8
UH-FC4-4N	1/4	1/4	1.54	39.1	0.18	4.6	3/4
UH-FC8-6N	1/2	3/8	1.76	44.7	0.40	10.2	15/16
UH-FC8-8N	1/2	1/2	1.99	50.5	0.40	10.2	1 1/16
UH-FC12-12N	3/4	3/4	2.36	59.9	0.62	15.7	1 5/16
UH-FC16-16N	1	1	2.51	63.8	0.87	22.1	1 5/8

Bulkhead Male NPT Connector

**BHMC-N**

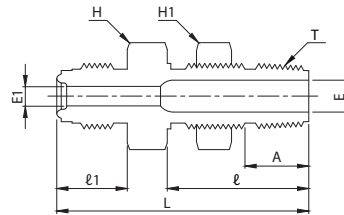

Part No.	Head Size (in.)	Size NPT T	L		ℓ1		A		E		E1		ℓ		H Hex (mm)	H1 Hex (mm)
			in.	mm	in.	mm	in.	mm	in.	mm	in.	mm	in.	mm		
UH-BHMC4-4N	1/4	1/4	2.21	56.1	0.62	15.7	0.56	14.2	0.28	7.1	0.18	4.6	1.24	31.5	20.63	20.63
UH-BHMC8-4N	1/2	1/4	2.34	59.4	0.75	19.1	0.56	14.2	0.28	7.1	0.4	10.2	1.24	31.5	23.81	20.63

Tube Butt Weld Bulkhead Connector

**BHTW**

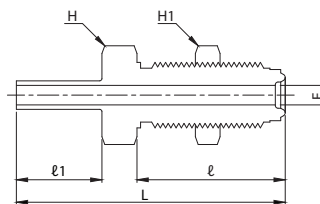

Part No.	Head Size (in.)	L		ℓ		ℓ1		E		H Hex (in.)	H1 Hex (in.)
		in.	mm	in.	mm	in.	mm	in.	mm		
UH-BHTW-4	1/4	2.36	59.9	1.3	33	0.75	19.1	0.18	4.6	3/4	3/4
UH-BHTW-4-495	1/4	1.95	49.5	0.99	25.1	0.75	19.1	0.18	4.6	3/4	3/4

Straight Thread O-Ring Seal Male Connector

**MC-UO**

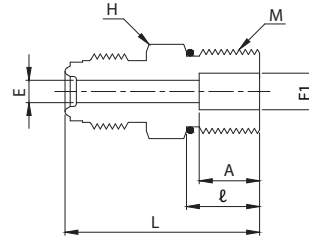

Part No.	Head Size (in.)	L		ℓ		A		E		E1		H Hex (in.)	M
		in.	mm	in.	mm	in.	mm	in.	mm	in.	mm		
UH-MC4-6U	1/4	1.33	33.8	0.39	9.9	0.25	6.4	0.18	4.6	0.28	7.1	3/4	9/16-18 UNF
UH-MC8-6U	1/2	1.48	37.6	0.39	9.9	-	-	0.28	7.1	0.28	7.1	15/16	9/16-18 UNF
UH-MC8-10U	1/2	1.66	42.2	0.5	12.7	0.4	10.2	0.28	7.1	0.59	15	1	7/8-14 UNF

Union Elbow

**L**

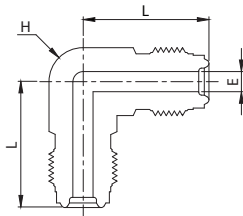

Part No.	Head Size (in.)	L		E		H Hex (in.)
		in.	mm	in.	mm	
UH-L-4	1/4	1.07	27.2	0.18	4.6	1/2
UH-L-8	1/2	1.45	36.8	0.40	10.2	13/16
UH-L-12	3/4	1.92	48.8	0.62	15.7	1 1/4
UH-L-16	1	2.00	50.8	0.87	22.1	1 11/16

Union Tee

**T**

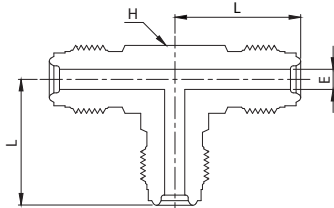

Part No.	Head Size (in.)	L		E		H Hex (in.)
		in.	mm	in.	mm	
UH-T-4	1/4	1.07	27.2	0.18	4.6	1/2
UH-T-8	1/2	1.45	36.8	0.40	10.2	13/16
UH-T-12	3/4	1.92	48.8	0.62	15.7	1 1/4
UH-T-16	1	2.00	50.8	0.87	22.1	1 11/16

## Union Cross Tee

### X

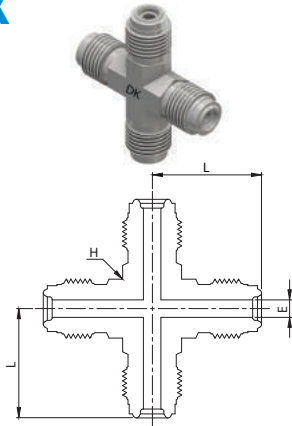

Part No.	Head Size (in.)	L		E		H Hex (in.)
		in.	mm	in.	mm	
UH-X-4	1/4	1.07	27.2	0.18	4.6	1/2
UH-X-8	1/2	1.45	36.8	0.40	10.2	13/16
UH-X-12	3/4	1.92	48.8	0.62	15.7	1 1/4
UH-X-16	1	2.00	50.8	0.87	22.1	1 11/16

## Male NPT Elbow

### ML-N

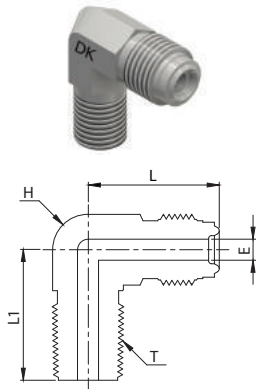

Part No.	Head Size (in.)	Size NPT T	L		L1		E		H Hex (in.)
			in.	mm	in.	mm	in.	mm	
UH-ML4-2N	1/4	1/8	1.07	27.2	0.87	22.1	0.18	4.6	1/2
UH-ML4-4N	1/4	1/4	1.07	27.2	1.05	26.7	0.18	4.6	1/2
UH-ML8-6N	1/2	3/8	1.45	36.8	1.26	32.0	0.4	10.2	13/16
UH-ML8-8N	1/2	1/2	1.45	36.8	1.45	36.8	0.4	10.2	13/16

## Coupling

### C

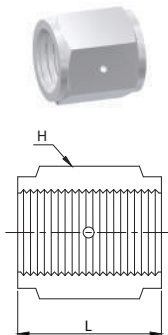

Part No.	Size (in.)	L		H Hex (in.)
		in.	mm	
U-C-2	1/8	0.66	16.8	7/16
U-C-4	1/4	1.19	30.2	3/4
U-C-8	1/2	1.31	33.3	1 1/16
U-C-12	3/4	1.68	42.7	1 1/2
U-C-16	1	2.04	51.8	1 3/4

## High Flow Fittings

High Flow Gland

### HG

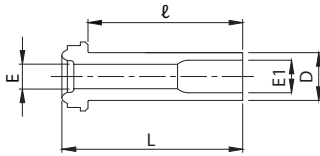

Part No.	Head Size (in.)	D	E1		E		L		ℓ	
			in.	mm	in.	mm	in.	mm	in.	mm
U-HG-4X6	1/4	3/8	0.31	7.9	0.25	6.4	1.31	33.3	1.12	28.4

High Flow Reducer

### HR

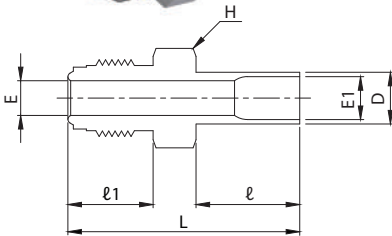

Part No.	Head Size (in.)	D	L		ℓ		ℓ1		E		E1		H Hex (in.)
			in.	mm	in.	mm	in.	mm	in.	mm	in.	mm	
U-HR-4X6	1/4	3/8	1.68	42.7	0.75	19.1	0.62	15.7	0.25	6.4	0.31	7.9	5/8

Auto Butt Weld High Flow Reducer

### HRA

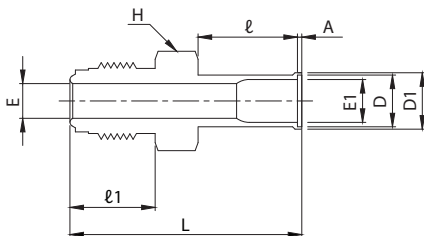

Part No.	Head Size (in.)	D	L		ℓ		ℓ1		A		E		E1		D1		H Hex (in.)
			in.	mm	in.	mm	in.	mm	in.	mm	in.	mm	in.	mm	in.	mm	
U-HRA-4X6	1/4	3/8	1.71	43.4	0.75	19.1	0.62	15.7	0.03	0.8	0.25	6.4	0.31	7.9	0.41	10.4	5/8

High Flow Bulkhead Reducer

**HBR**



Part No.	Head Size (in.)	D	L		ℓ		ℓ1		E		E1		H Hex (in.)	H1 Hex (in.)
			in.	mm	in.	mm	in.	mm	in.	mm	in.	mm		
U-HBR-4X6	1/4	3/8	2.36	59.9	0.75	19.1	1.3	33	0.25	6.4	0.31	7.9	3/4	3/4

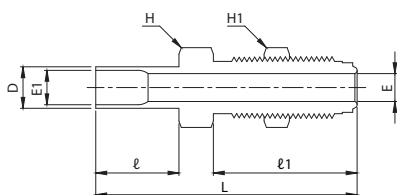

High Flow Union Elbow

**HL**



Part No.	Head Size (in.)	L		E		H Hex (in.)
		in.	mm	in.	mm	
U-HL-4	1/4	1.07	27.2	0.25	6.4	1/2

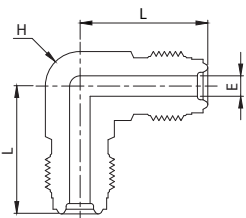

High Flow Union Tee

**HT**



Part No.	Head Size (in.)	L		E		H Hex (mm)
		in.	mm	in.	mm	
U-HT-4	1/4	1.07	27.2	0.25	6.4	12.7

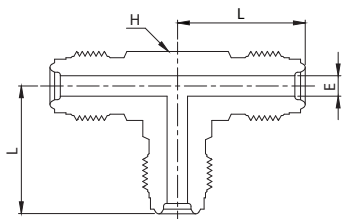

High Flow Female Nut

**HFN**

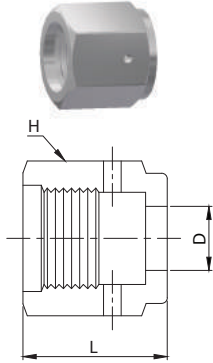

Part No.	Head Size (in.)	L		D		H Hex (in.)
		in.	mm	in.	mm	
U-HFN-4	1/4	0.81	20.6	0.39	9.9	3/4

High Flow Male Nut

**HMN**

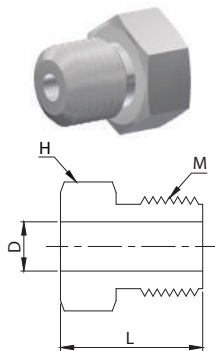

Part No.	Head Size (in.)	L		D		H Hex (in.)	M
		in.	mm	in.	mm		
U-HMN-4	1/4	0.71	18.0	0.39	9.9	5/8	9/16-18 UNF

Tube Fitting to Auto Butt Weld Connector

**DATW**

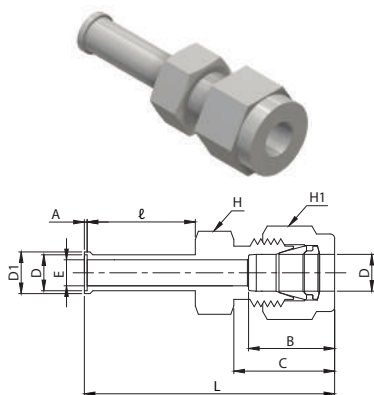

Part No.	Head Size (in.)	D	D1		L		l		A		B		C		E		H Hex (in.)	H1 Hex (in.)
			in.	mm	in.	mm	in.	mm	in.	mm	in.	mm	in.	mm	in.	mm		
U-DATW-4X4	1/4	1/4	0.29	7.4	1.74	44.2	0.75	19.1	0.02	0.5	0.60	15.2	0.70	17.8	0.18	4.6	1/2	9/16
U-DATW-6X6	3/8	3/8	0.41	10.4	1.84	46.7	0.75	19.1	0.02	0.5	0.22	16.8	0.76	19.3	0.31	7.9	5/8	11/16

## Welded Assembly Fittings

Swivel Female / Male Union

### SFMU

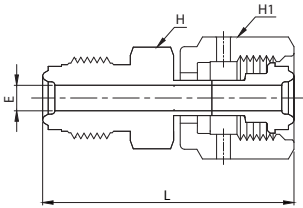

Part No.	Head Size (in.)	L		E		H Hex (in.)	H1 Hex (in.)
		in.	mm	in.	mm		
U-SFMU-4	1/4	1.78	45.3	0.18	4.6	5/8	3/4

Swivel Female Union

### SFU

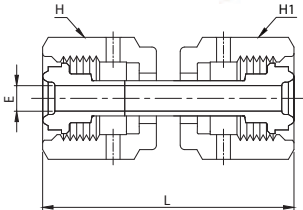

Part No.	Head Size (in.)	L		E		H Hex (in.)	H1 Hex (in.)
		in.	mm	in.	mm		
U-SFU-4	1/4	1.71	43.4	0.18	4.6	3/4	3/4
U-SFU-8	1/2	1.84	46.7	0.40	10.2	1 1/16	1 1/16

Swivel Male NPT Connector

### SMC-N

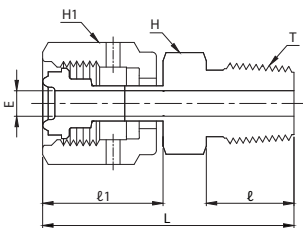

Part No.	Head Size (in.)	Size NPT T	L		ℓ		ℓ1		E		H Hex (in.)	H1 Hex (in.)
			in.	mm	in.	mm	in.	mm	in.	mm		
U-SMC4-2N	1/4	1/8	1.58	40.1	0.38	9.6	0.95	24.1	0.18	4.6	7/16	3/4
U-SMC4-4N	1/4	1/4	1.79	45.5	0.56	14.2	0.92	23.4	0.18	4.6	9/16	3/4
U-SMC8-6N	1/2	3/8	1.89	48.0	0.56	14.2	1.0	25.4	0.40	10.2	11/16	1 1/16
U-SMC8-8N	1/2	1/2	2.09	53.1	0.75	19.1	1.01	25.6	0.40	10.2	7/8	1 1/16

Swivel Female NPT Connector

**SFC-N**

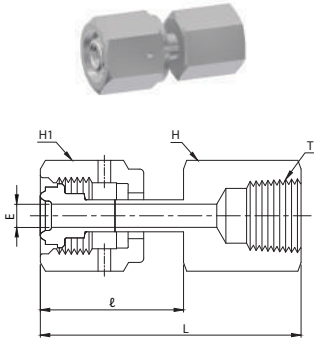

Part No.	Head Size (in.)	Size NPT T	L		ℓ		E		H Hex (in.)	H1 Hex (in.)
			in.	mm	in.	mm	in.	mm		
U-SFC4-4N	1/4	1/4	1.77	45.0	0.92	23.4	0.18	4.6	3/4	3/4
U-SFC8-6N	1/2	3/8	1.95	49.5	1.06	26.9	0.40	10.2	7/8	1 1/16
U-SFC8-8N	1/2	1/2	2.18	55.4	1.04	26.4	0.40	10.2	1 1/16	1 1/16

Swivel Tube Fitting Connector

**SDC**

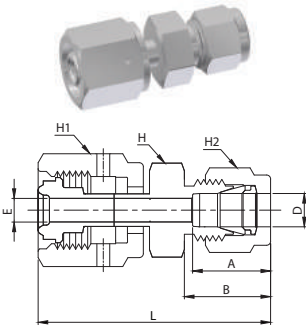

Part No.	Head Size (in.)	Size NPT D	L		A		B		E		H Hex (in.)	H1 Hex (in.)	H2 Hex (in.)
			in.	mm	in.	mm	in.	mm	in.	mm			
U-SDC-4	1/4	1/4	1.94	49.3	0.60	15.2	0.70	17.8	0.18	4.6	1/2	3/4	9/16

Swivel Elbow

**SL**

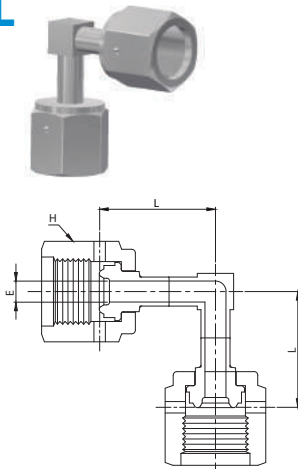

Part No.	Head Size (in.)	L		E		H Hex (in.)
		in.	mm	in.	mm	
U-SL-4	1/4	1.0	25.4	0.18	4.6	3/4

Swivel Tee

**ST**



Part No.	Head Size (in.)	L		E		H Hex (in.)
		in.	mm	in.	mm	
U-ST-4	1/4	1.0	25.4	0.18	4.6	3/4

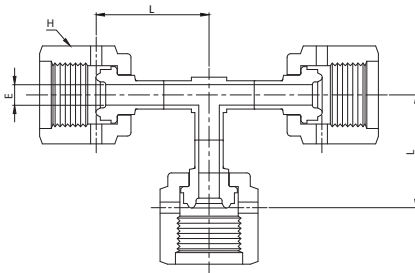

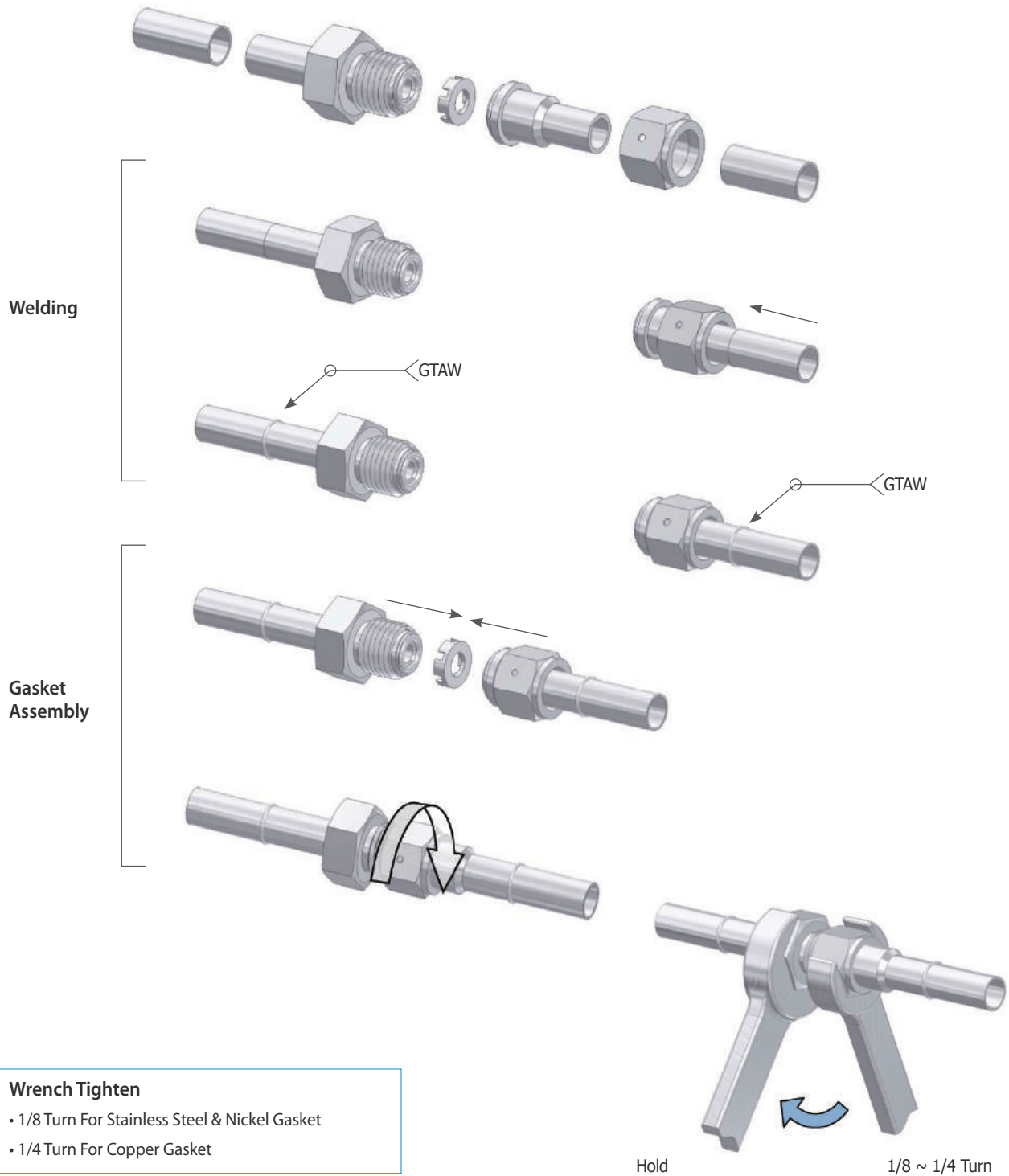

**Wrench Tighten**

- 1/8 Turn For Stainless Steel & Nickel Gasket
- 1/4 Turn For Copper Gasket



### Safe Component Selection

The selection of component for any applications or system design must be considered to ensure safe performance. Component function, material compatibility, component ratings, proper installation, operation and maintenance remain the sole responsibility of the system designer and the user. DK-Lok accepts no liability for any improper selection, installation, operation or maintenance.