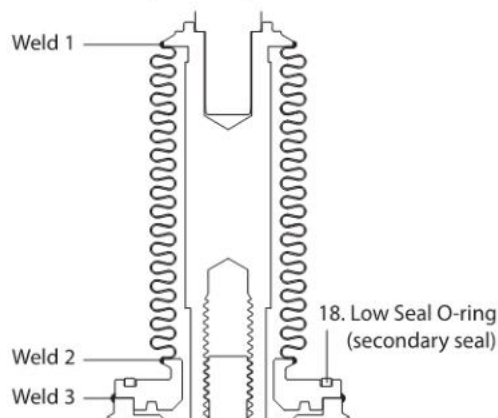

**Figure 1.**  
**Bellows Subassembly (Primary Seal)**



**Features**

V13W series bellows valve offers the most difficult fluid handling applications. This design with the secondary sealing system fits to the need for a safe and reliable system.

Applications include cryogenic to high temperatures, high pressure to vacuum in power plants, instrumentation, panels, and critical sampling system for toxic, radioactive, and hazardous fluids.

**Bellows subassembly (Figure 1)**

Welding upper end of the bellows to 12. stem (weld 1) and the other end to 19. stem weld ring (weld 2), this bellows is then welded to the valve body (weld 3).

Bellows subassembly with the three places of welding provides all metal, hermetical sealed valve. This primary seal offers a complete sealing between the system and atmosphere where leakage is not accepted.

**Secondary seal (6), (18).**

All welded stainless steel valves with secondary seal makes this valve for the most difficult fluid containment applications. Secondary sealing prevents leakage to atmosphere in the event of a bellows rupture due to excessive pressurization. Leakage past the primary seal is contained by secondary seal.

**Actuator threads (2)**

Hardened 440C stainless steel actuator is for maximum strength, wear resistance, and positive stem retraction.

Acme power transmission threads constructed on actuator (2) and the bonnet (8) for low operation torque and to handle the extreme force transmitted to the threads in high pressure bellows valve. The threads are not in contact with the process fluid and are protected from atmospheric containments by the packing (6).

**Valve actuation**

Valves in high pressure tend to stick in the closed position. The ball bearing (9), and double pin (10) on a shoulder of stem extension (11) provide positive lifting of stem (12) and stem retraction. Compressing or stretching the bellows allows linear motion of the stem with the convolutions.

**Ported bonnet nut (15)**

This allows monitoring sealing condition of weld 3 (Figure 1) and low seal O-ring (18).

**Turns to Open**

Bellows valves operated by manual actuating bar handle requires around 1 3/4 turns on the V13WA series and 2 1/2 turns on the V13WB & V13WC series to open the valves to full flow.

A jam nut (4) is provided for locking the gland nut (3).

**Additional Features**

- Non-rotating stem disc (17).
- Standard panel (14) and bottom mounting.
- Union bonnet construction allows packing (6) replacement for maintenance.
- Safety back-seat sealing in the valve closed position.
- DK-Lok tube fitting and socket or butt weld end connections.
- Regulating stem disc for V13WA series.

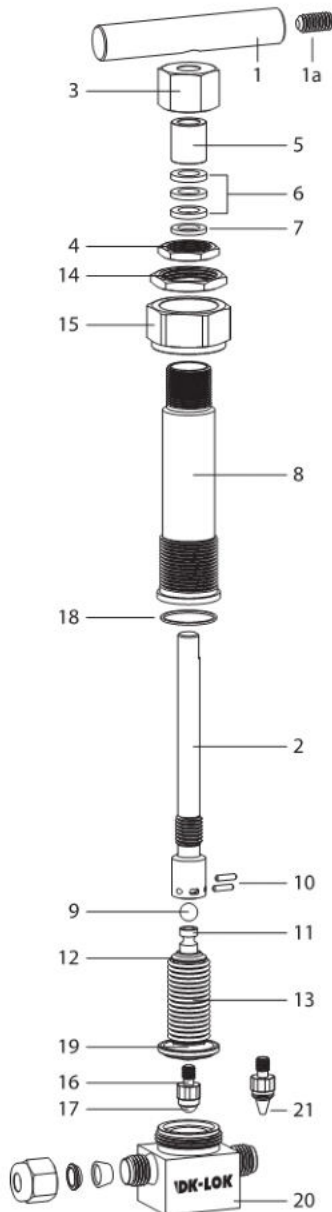

**Materials of Construction**

Component	Material Grade/ASTM specification
1. Handle	Aluminum Blue-anodized /B211
1a. Set Screw	Alloy Steel/ANSI 18.3
2. Actuator	440C SS/A276
3. Gland Nut	316SS/A479 or A276
4. Jam Nut	316SS/A479 or A276
5. Gland	316SS/A479 or A276
6. Packing	GRAFOIL, optional PTFE/D1710
7. Spacer	316SS/A479 or A276
8. Bonnet	316SS/A479 or A276
9. Ball Bearing	316SS/A479 or A276
10. Pin (2)	416SS
11. Stem Extension	440CSS/A276 or A276
12. Stem	316SS/A479 or A276
13. Bellows	Type 321 /A240 or 1.4541-DIN EN10028-7
14. Panel Mount Nut	316SS/A479 or A276
15. Bonnet Nut	316SS/A479 or A276
16. Stem Adapter	316SS/A479 or A276
17. Spherical stem disc	Cobalt alloy/AMS 5373
21. Optional regulating stem disc	316SS/A479 or A276
18. Low Seal O-Ring	316SS/A479
19. Stem Weld Ring	316SS/A479
20. Body	316SS/A479

Wetted parts and lubricants are listed in blue.

**Lubricants**

Spherical stem disc : Fluorinated-based.  
Non-wetted lubricant : Silicon based

**Factory test**

Every bellows valve is vacuum-tested with helium at room temperature for 5s to a maximum leak rate of  $4 \times 10^{-9}$  std cm<sup>3</sup>/s at the seat, envelope, and all seals.

**Cleaning and Packaging**

Every bellows valve is cleaned and packaged in accordance with DK-Lok Corporation cleaning standard DC-01. Optional DC-11 cleaning for oxygen application is available on request.

**Ordering Information and Dimensions**

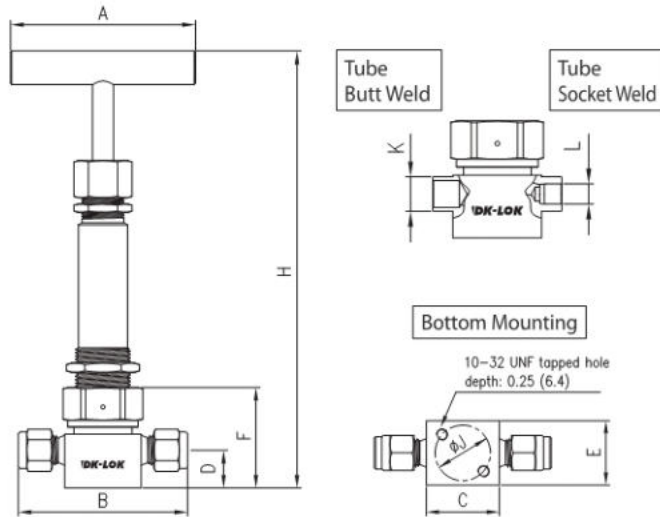

Basic Ordering Number	End Connections		Orifice	Dimensions, in (mm)										
	Inlet	Outlet		B	C	D	E	F	H	J	K	L	A	
V13WA-	D4T-	1/4 in. DK-Lok	0.172 (4.37)	2.46 (62.5)								-	-	2.75 (69.9)
	D6M-	6mm DK-Lok	0.172 (4.37)	2.46 (62.5)	1.13 (28.7)	0.56 (14.2)	1.00 (25.4)	1.49 (37.8)	6.45 (164)	1.00 (25.4)	-	-		
	SW4T-	1/4 in. Tube Socket Weld	0.156 (3.96)	1.68 (42.7)							0.38 (9.7)	0.25 (6.4)		
	W6T-	3/8 in. Tube Butt Weld	0.156 (3.96)	1.68 (42.7)										
V13WB-	D6T-	3/8 in. DK-Lok	0.265 (6.73)	3.09 (78.5)								-	-	
	D10M-	10mm DK-Lok	0.281 (7.14)	3.11 (79.0)	1.57 (39.9)	0.50 (12.7)	1.13 (28.7)	1.61 (40.9)	6.59 (167)	1.13 (28.7)	-	-		
	SW6T-	3/8 in. Tube Socket Weld	0.281 (7.14)	2.27 (57.7)							0.50 (12.7)	0.38 (9.7)		
	W8T-	1/2 in. Tube Butt Weld	0.281 (7.14)	2.27 (57.7)										
V13WC-	D8T-	1/2 in. DK-Lok	0.312 (7.92)	3.30 (83.8)								-	-	
	D12M-	12mm DK-Lok	0.281 (7.14)	3.30 (83.8)	1.57 (39.9)	0.50 (12.7)	1.13 (28.7)	1.61 (40.9)	6.59 (167)	1.13 (28.7)	-	-		
	SW8T-	1/2 in. Tube Socket Weld	0.312 (7.92)	2.27 (57.7)							0.75 (19.1)	0.50 (12.7)		
	W12T-	3/4 in. Tube Butt Weld	0.312 (7.92)	2.27 (57.7)										

**Ordering information.**

Select the desired valve basic ordering number, and optional disc.

**Note :**

Optional regulating disc is applicable only to V13WA series

V13WA-D4T-



**Pressure-Temperature Ratings**

Ratings are for SS316 valves with spherical and regulating stem disc.

Temperature, °F (°C)	Working Pressure, psig (bar)
-20 to 650 (-28 to 343)	2500 (172)
700 (371)	2120 (146)
750 (398)	1740 (119)
800 (426)	1360 (93.7)
850 (454)	980 (67.5)
900 (482)	600 (41.3)
950 (510)	540 (37.2)
1000 (537)	480 (33.0)
1050 (565)	425 (29.2)
1100 (593)	360 (24.8)
1150 (621)	300 (20.6)
1200 (648)	250(17.2)

**Technical Data**

Valve series	Stem disc	Cv	Internal Volume in.3(cm3)
V13WA	Standard spherical	0.36	0.11 (1.8)
V13WB		1.0	0.25 (4.1)
V13WC		1.2	0.27 (4.4)
V13WA	Optional regulating	0.36	0.11 (1.8)

**Flow Data @ 70 °F (20 °C)**

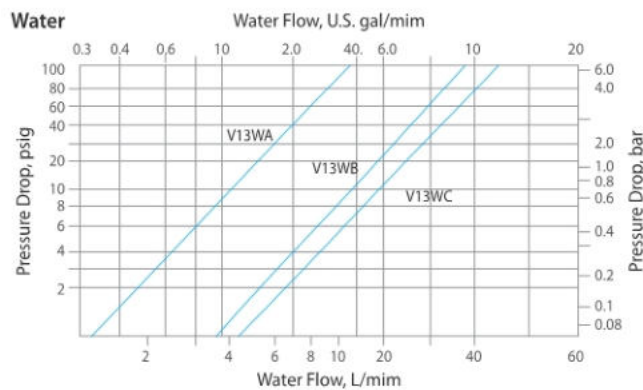
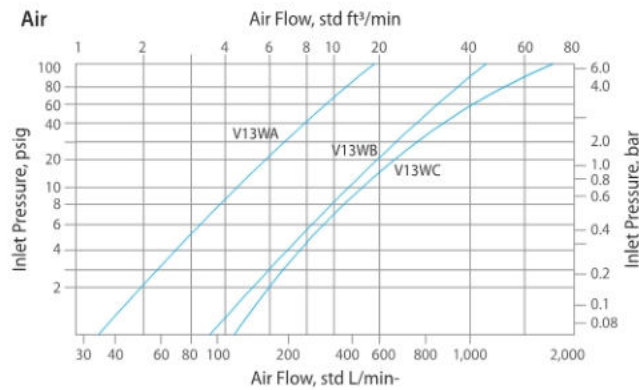

**Flow Coefficient at Turns Open**

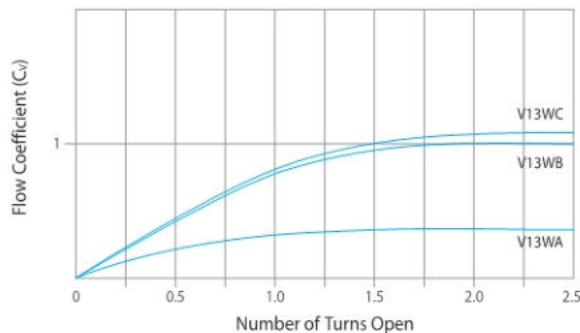

We reserve the right to change specifications stated in this catalog for our continuing program of improvement.

**Safe Valve Selection**

The Selection of a valve for any application or system design must be considered to ensure safe performance. Valves function, valve rating, material compatibility, proper installation, operation and maintenance remain the sole responsibility of the system designer and the user. DK-Lok accepts no liability for any improper selection, installation, operation or maintenance.

 <p><b>DK-LOK</b> Fittings &amp; Valves www.dklok.com</p>	<p><b>DK-LOK Corporation</b></p> <p>Mailing Address 7, Golden root-ro 129beon-gil, Juchon-myeon, Gimhae-si, Gyeongsangnam-do, South Korea 621-842</p>	<p>DK-Lok contact information</p> <p>Tel. (82) 55-338-0114 Fax. (82) 55-901-0143 E-mail : sales@dklok.com</p>	<p>For International customers</p> <p>Tel. (82) 55-338-0031/2 Fax. (82) 55-901-0142 E-mail : dklok@dklok.com</p>
------------------------------------------------------------------------------------------------------------------------------------------------------	---------------------------------------------------------------------------------------------------------------------------------------------------------------	-----------------------------------------------------------------------------------------------------------------------	--------------------------------------------------------------------------------------------------------------------------