

VM 1D, 3D, and 6D Series

Features

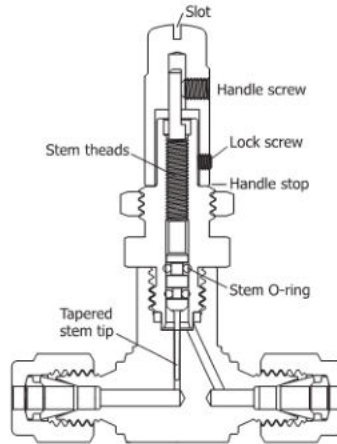

- **Slotted handle**
allows flow setting adjustment with a screwdriver.
- **Lock screw**
locks out flow setting.
- **Stem threads**
are isolated from system fluid.
- **Handle stop**
mechanically helps prevent damage to stem and orifice.
- **Stem O-ring**
seals system fluids
- **Tapered stem tip**
controls gas or liquid flow rates accurately.
- **Body materials**
are forged stainless steel 316 or brass.
Straight and angle patterns.
Standard Panel mounting.

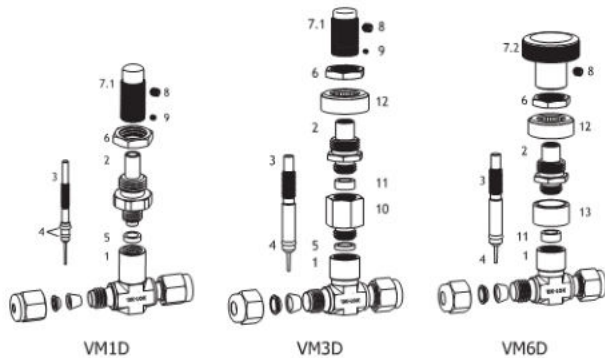

Panel mount : VM1D & 3D series with standard L and optional SL handle allow valve panel mount with no handle removal.

Table 1. Material of Construction

Component	Valve Body Materials Grade/ASTM Specification	
	Stainless Steel	Brass
1. Body	F316/A182	C37700/B283
2. Bonnet	SS316/A276	C34500/B453
3. Stem	S17400/A564 for VM1D, A276 for VM3D & VM6D	
4. Stem o-ring	FKM	Buna N
5. Body seal	PTFE	
6. Panel nut	SS316/A276	C36000/B16
7-1. Handle	SS300/A276	C36000/B16
7-2. Round handle	Aluminum 6061	
8. Handle set screw	Alloy steel	
9. Lock screw	Alloy steel	
10. Body extension	SS316/A276	C34500/B453
11. Stem guide ring	Glass-filled PTFE	
12. Bonnet sleeve	Sintered SS316	
13. Body support ring	SS316	

- Wetted components listed in blue.
- Lubricant : Molybdenum disulfide-based; silicon-based.

Factory Test

Every valve is factory tested with nitrogen gas at 68.9bar (1,000 psig) and required to no detectable leakage. Hydraulic shell test is optionally performed at 1.5 times the working pressure.

Cleaning and Packaging

Every valve is cleaned and packaged in accordance with DK-Lok Corporation cleaning standard of DC-01. Optional DC-11 cleaning for oxygen application is available on request.

Table 2. Temperature Rating

Standard O-ring material	Designator	Temperature Rating °F (°C)
FKM standard for SS316 body	VT	-10 to 400 (-23 to 204)
NBR standard for brass body	BN	-10 to 300 (-23 to 148)
Optional Kalrez [®]	KZ	0 to 300 (-17 to 148)

Table 3. Technical Data

Series	VM1D	VM3D	VM6D
Working pressure psig (bar)	2,000 (137)	1,000 (68.9)*	
Orifice in. (mm)	0.032 (0.81)	0.056 (1.42)	0.128 (3.25)
Stem taper	1°	3°	6°
Cv	0.004	0.03	0.16
Turns to Open	8 to 12	8 to 10	10 to 11
Internal volume cu.in (cu.mm)	0.006 (98)	0.028 (460)	0.035 (570)
Flow shut off	No	No	Yes**

* While valve is adjusted at pressure, 500 psig (34.4 bar) is max downstream pressure due to mechanical strength limit of the finepitch threads and high operation torque.

** VM6D series in use for shutoff in vacuum or gas, or for repetitive shutoff in liquid are not recommendable.

Table 4. Turns Open and Flow Data

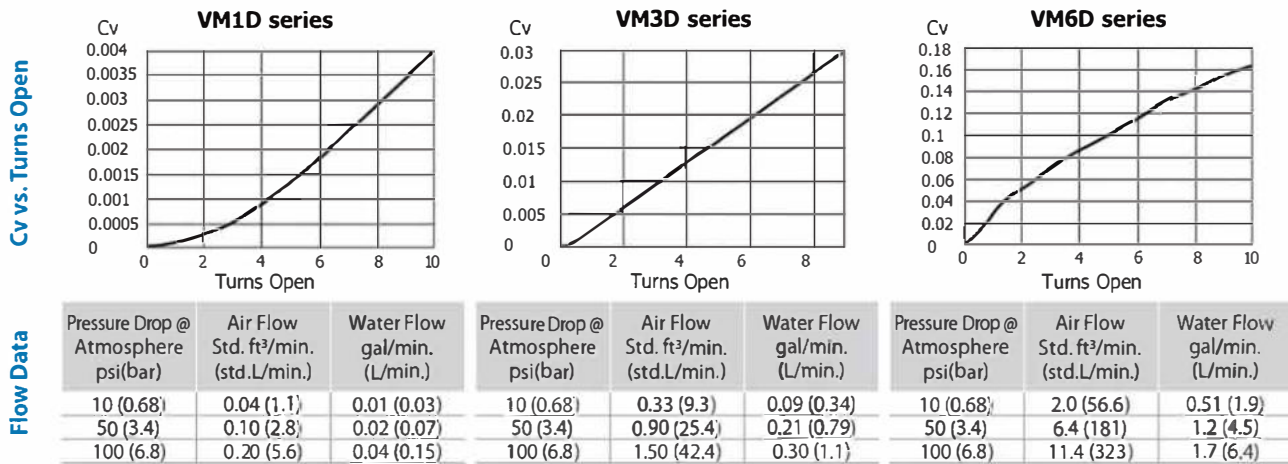

Ordering Information and Dimensions

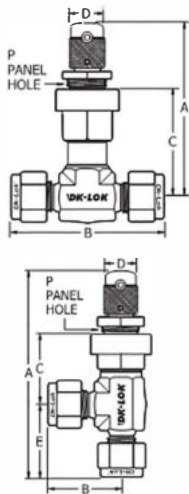

Basic Ordering Number	Angle pattern	End Connections Inlet & Outlet	Dimensions in. (mm)					
			A	B	C	D	E	
VM1D-		D1T- 1/16 in. DK-Lok	2.34 (59.4)	1.56 (39.6)	0.92 (23.4)	0.38 (9.6)	-	
		D2T- 1/8 in. DK-Lok		1.90 (48.3)				
		D4T- 1/4 in. DK-Lok		2.04 (51.8)				
		D3M- 3mm DK-Lok		1.90 (48.3)				
		D6M- 6mm DK-Lok		2.04 (51.8)				
		D1T- A- 1/16 in. DK-Lok		3.22 (81.8)				0.81 (20.6)
VM3D-		D2T- 1/8 in. DK-Lok	2.78 (70.6)	2.02 (51.3)	1.56 (39.6)	0.50 (12.7)	-	
		D4T- 1/4 in. DK-Lok		2.20 (55.9)				
		D3M- 3mm DK-Lok		2.02 (51.3)				
		D6M- 6mm DK-Lok		2.20 (55.9)				
		D2T- A- 1/8 in. DK-Lok	3.30 (83.8)	1.01 (25.7)	1.01 (25.7)			
		D4T- A- 1/4 in. DK-Lok	3.39 (86.1)	1.10 (27.9)	1.10 (27.9)			
		M2N- 1/8 in. Male NPT	2.78 (70.6)	1.50 (38.1)	-			
		M4N- 1/4 in. Male NPT	1.96 (49.8)	1.56 (39.6)				
		F2N- 1/8 in. Female NPT	2.78 (70.6)	1.94 (49.3)				
		F2N- A- 1/8 in. Female NPT	3.26 (82.8)	0.98 (24.9)		1.07 (27.2)	0.97 (24.6)	
VM6D-		D4T- 1/4 in. DK-Lok	2.82 (71.6)	2.34 (59.4)	1.13 (28.7)	-		
		D6T- 3/8 in. DK-Lok		2.46 (62.5)				
		D6M- 6mm DK-Lok		2.34 (59.4)				
		D4T- A- 1/4 in. DK-Lok	3.77 (95.8)	1.17 (29.7)			1.04 (26.4)	1.17 (29.7)
		M4N- 1/4 in. Male NPT	2.82 (71.6)	2.00 (50.8)			1.26 (32.0)	-

Dimensions shown are for reference only and are subject to change. Dimensions with DK-Lok nuts are in finger-tight position.

Standard and Optional Handles

Lock screw handle allows locking the set flow, standard for 1D and 3D series.	Slotted handle helps flow setting adjustment with a screwdriver.
Vernier handle made out of aluminum helps ensure repeatable flow setting in readings accurate to 1/25th turn.	Adjustable-torque handle enhances control for setting flows with two top-mounted adjustment screws.

How to Order Select desired valve basic ordering number, optional handle, O-ring and body material designators.

VM1D-D2T

Handle Designators	- V				Nil : L is standard for 1D and 3D series V : Optional to 1D,3D, and 6D series SL : Optional to 1D and 3D series ATH : Optional to 1D series Nil : Round handle (designator -R) standard for 6D series Note : Chrome plated brass handle supplied on brass valve.	- KZ		- S	
	L Lock screw handle	V Vernier handle	SL Slotted handle	ATH Adjustable-Torque handle		O-ring Designators Nil : VT standard for stainless body. Nil : BN standard for brass body. • VT : Viton • BN : NBR • KZ : Kalrez	Body material Designators S : SS316 B : Brass		

VMH Series

Features

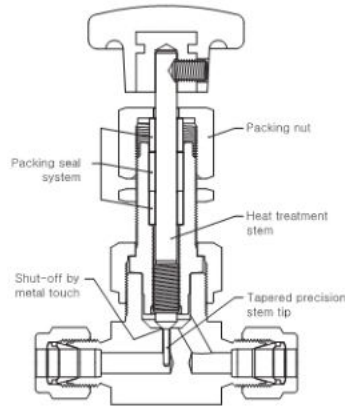

- **Packing Seal System**
prevents protrusion of packing caused by internal pressure
- **Metal To Metal Shut Off**
leak free performance between the stem and body seat
- **Packing Nut**
externally adjustable
- **Heat Treated Stem**
improves endurance life
- **Tapered Precision Stem Tip**
ensures accurate flow control

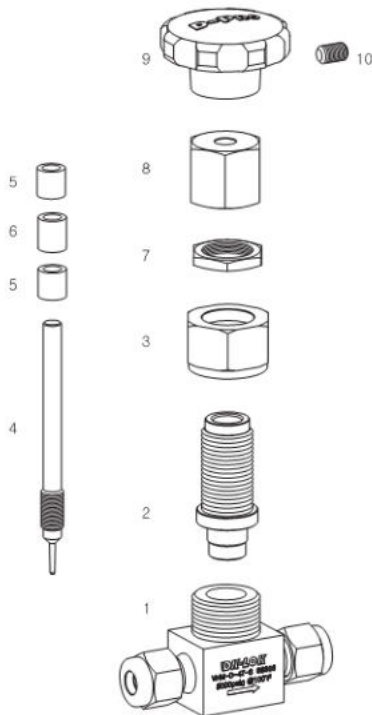

Table 4. Material of Construction

Component	Grade/ASTM Specification
1. Body	SS316/A276
2. Bonnet	SS316/A276
3. Union nut	SS316/A276
4. Stem	SS440/A276
5. Gland	SS316/A276
6. Packing	PTFE/D1710
7. Panel nut	SS316/A276
8. Packing nut	SS316/A276
9. Handle	Nylon with brass insert
10. Handle set screw	Alloy steel

Table 5. Pressure vs. Temperature Ratings

ASME Class	2080
Material Group	2.2
Material Name	SS316
Temperature, °F (°C)	Working pressure, psig (bar)
-65~100 (-53~38)	5,000 (344)
200 (93)	4,295 (295)
300 (148)	3,875 (266)
400 (204)	3,560 (245)
450 (232)	3,435 (236)
500 (260)	3,310 (228)
600 (315)	3,130 (215)
650 (343)	3,080 (212)
700 (371)	3,000 (206)
750 (398)	2,930 (201)
800 (426)	2,880 (198)
850 (454)	2,815 (193)

Standard PTFE packing is up to 450°F (232°C), optional Grafoil packing is up to 850°F (454°C)

Factory Test

Every valve is factory tested with nitrogen gas at 68.9 bar (1,000 psig) for leakage to a maximum allowable leak rate of 0.1 SCCM at seat.

Cleaning and Packaging

Every valve is cleaned and packaged in accordance with DK-Lok Corporation cleaning standard of DC-01. Optional DC-11 cleaning for oxygen application is available on request.

Table 6. Turns Open and Flow Data

Cv vs. Turns Open

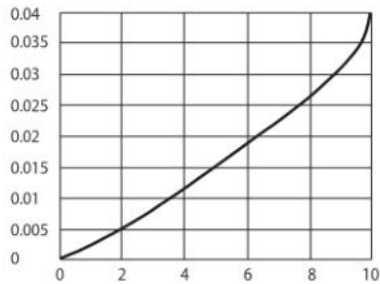

Flow Data

Pressure Drop @ Atmosphere psi(bar)	Air Flow Std. ft ³ /min. (std.L/min.)	Water Flow Gal/min. (L/min.)
10 (0.68)	0.45 (12.7)	0.12 (0.45)
50 (3.4)	1.2 (33.9)	0.28 (1.0)
100 (6.8)	2.1 (59.4)	0.4 (1.5)

Ordering Information and Dimensions

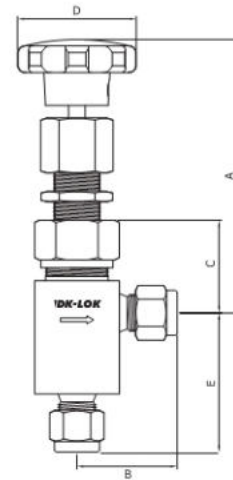
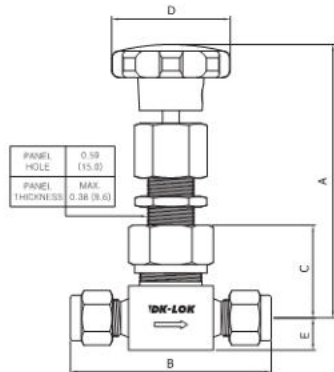

Basic Ordering Number	Angle pattern	End Connections Inlet & Outlet	Dimensions in. (mm)				
			A	B	C	D	E
VMH-	D4T-	1/4 in. DK-Lok	3.6 (91.4)	2.4 (61.0)	1.09 (27.7)	1.42 (36.0)	0.38 (9.6)
	D6M-	6 mm DK-Lok					
	D4T-	1/4 in. DK-Lok					
	D6M-	6 mm DK-Lok					
	F2N-	1/8 in. Female NPT	3.6 (91.4)	2.0 (50.8)	1.09 (27.7)	1.42 (36.0)	0.38 (9.6)
	F4N-	1/4 in. Female NPT					
	F2N-	1/8 in. Female NPT	3.8 (96.5)	2.0 (50.8)			
	F4N-	1/4 in. Female NPT					

Dimensions shown are for reference only and are subject to change. Dimensions are with DK-Lok nuts in the finger-tight position.

How to Order

VMH-D4T-GF

BL

- S

Packing designators	Handle colors		Body material designator
Nil : PTFE GF : Grafoil	Handle color	Designator	S : SS316
	Black	Nil	
	Red	RD	
	Blue	BL	

IDK-LOK
Fittings & Valves
www.dklok.com

IDK-LOK Corporation
Mailing Address
7, Golden root-ro 129beon-gil, Juchon-myeon, Gimhae-si, Gyeongsangnam-do, South Korea 621-842

DK-Lok contact information
Tel. (82) 55-338-0114
Fax. (82) 55-901-0143
E-mail : sales@dklok.com

For International customers
Tel. (82) 55-338-0031/2
Fax. (82) 55-901-0142
E-mail : dklok@dklok.com